



i200

Dive Computer Owner's Manual

NOTICES

LIMITED TWO-YEAR WARRANTY

For warranty details and to register your product, refer to www.aqualung.com.

COPYRIGHT NOTICE

This owner's manual is copyrighted, all rights are reserved. It may not, in whole or in part, be copied, photocopied, reproduced, translated, or transferred to any other form without prior consent in writing from Aqua Lung.

i200 Dive Computer Owner's Manual, Doc. No. 12-7848
© Aqua Lung International, Inc., 2016
Vista, CA USA 92081

TRADEMARK, TRADE NAME, AND SERVICE MARK NOTICE

Aqua Lung, the Aqua Lung logo, i200, the i200 logo, Diver Replaceable Batteries, Graphic Diver Interface, Pre-Dive Planning Sequence (PDPS), SmartGlo, Set Point, Control Console, Turn Gas Alarm, and Aqua Lung computer Interface (ALI) are all registered and unregistered trade-marks, trade names, and service marks of Aqua Lung. All rights are reserved.

PATENT NOTICE





U.S. Patents have been issued to protect the following design features, GTR/Air Time Remaining (U.S. Patent no. 4,586,136 and 6,543,444) and Data Sensing and Processing Device (U.S. Patent no. 4,882,678). Set Tissue Loading Bar Graph Alarm (NIBG Alarm) and other patents pending. User Setable Display (U.S. Patent no. 5,845,235) is owned by Suunto Oy (Finland).

DECOMPRESSION MODEL

The program within the i200 simulates the absorption of inert gases into the body by using a mathematical model. This model is merely a way to apply a limited set of data to a large range of experiences. The i200 dive computer model is based upon the latest research and experiments in decompression theory. Still, using the i200, just as using any other No Decompression Tables, is no guarantee of avoiding decompression sickness, i.e. "the bends". Every diver's physiology is different, and can even vary from day to day. No machine can predict how your body will react to a particular dive profile.

DANGERS, WARNINGS, CAUTIONS, AND NOTES

Pay attention to the following symbols when they appear throughout this document. They denote important information and tips.

-  **DANGERS:** are indicators of important information that if ignored **would** lead to severe injury or death.
-  **WARNINGS:** are indicators of important information that if ignored **could** lead to severe injury or death.
-  **CAUTIONS:** indicate information that will help you avoid faulty assembly, leading to an unsafe condition.
-  **NOTES:** indicate tips and advice that can inform of features, aid assembly, or prevent damage to the product.

RESPONSIBLE COMPUTER DIVING

- Always plan each dive.
- Always limit your dive to the level of your training and experience.
- Always make your deepest dive first.
- Always make the deepest part of every dive first.
- Check your computer often during the dive.
- Do a safety stop on every dive.
- Allow adequate surface interval between each dive.
- Allow adequate surface interval between each day of diving (12 Hours or until your computer clears).
- Read and understand this manual thoroughly before using the i200.



WARNINGS:

- The i200 is intended for use by recreational divers who have successfully completed an internationally recognized course in scuba diving (for air use) and diving with enriched nitrogen-oxygen (nitrox) breathing gas mixtures (for nitrox use).
- It must not be used by untrained persons who may not have knowledge of the potential risks and hazards of scuba diving and diving with enriched nitrogen-oxygen (nitrox) mixtures.
- You must obtain scuba certification in diving with enriched nitrogen-oxygen mixtures (nitrox) before using the i200 for nitrox diving.
- It is NOT for use by military and commercial divers.
- As with all underwater life support equipment, improper use or misuse of this product can cause serious injury or death.
- Never participate in sharing or swapping of a dive computer.
- Conduct your dives in such a manner so as to insure that you continuously check the computer's proper function.
- Read and understand this owner's manual completely before diving with the i200.
- If you do not fully understand how to use this dive computer or if you have any questions, you should seek instruction in its use from your authorized Aqua Lung dealer before you utilize this product.
- If your i200 stops working for any reason while operating, it is important that you have anticipated this possibility and are prepared for it. This is an important reason for not pushing the tables, oxygen exposure limits, or entering decompression without proper training. If you dive in situations where your trip would be ruined or your safety would be jeopardized by losing the use of your i200, a backup instrument system is highly recommended.
- Each numeric and graphic display represents a unique piece of information. It is imperative that you understand the formats, ranges, and values of the information represented to avoid any possible misunderstanding that could result in error.
- Remember that technology is no substitute for common sense. The dive computer only provides the person using it with data, not the knowledge to use it. Remember also that the dive computer does not actually measure and test the composition of your body tissue and blood. Using an Aqua Lung dive computer, just as using any other Decompression Tables, is no guarantee of avoiding decompression sickness. Every diver's physiology is different and can even vary from day to day. No machine can predict how your body will react to a particular dive profile.
- Diving at high altitude requires special knowledge of the variations imposed upon divers, their activities, and their equipment by the decrease in atmospheric pressures. Aqua Lung recommends completion of a specialized altitude training course by a recognized training agency prior to diving in high altitude lakes or rivers.
- Repetitive dives in a series should only be conducted at the same altitude as that of the first dive of that series. Repetitive dives made at a different altitude will result in an error equal to the difference in barometric pressure, and possibly a false dive mode with erroneous data.
- If the i200 is activated at an elevation higher than 4,270 m (14,000 ft), it will immediately shutdown.
- Decompression diving or diving deeper than 39 m (130 ft) will greatly increase your risk of decompression sickness. This should only be attempted by those properly trained and certified in decompression diving. It is important to completely understand the features, functions, and specifically the limitations of the i200. Based on this the diver must decide if the i200 is suitable for the dive activities and dive profiles being planned.
- Using an i200 is no guarantee of avoiding decompression sickness.
- The i200 enters Violation Mode when a situation exceeds its capacity to predict an ascent procedure. These dives represent gross excursions into decompression that are beyond the boundaries and spirit of the i200's design. If you are following these dive profiles, Aqua Lung advises that you should not use an i200.
- If you exceed certain limits, the i200 will not be able to help you get safely back to the surface. These situations exceed tested limits and can result in loss of some functions for 24 hours after the dive in which a violation occurred.

CONTENTS

NOTICES	2	4. TLBG (Tissue Loading Bar Graph) ALARM	31
RESPONSIBLE COMPUTER DIVING	2	5. DTR (Dive Time Remaining) ALARM	31
WARNINGS:	3	6. PO ₂ Alarm	32
GETTING STARTED	6	SET UTILITIES	32
BASICS	7	1. H2O ACTIVATION	32
INITIAL ACTIVATION	7	2. UNITS (IMP/MET)	33
DISPLAY ICONS	8	3. DEEP STOP	33
BUTTONS	9	4. SAFETY STOP	34
BUTTON FUNCTIONS	10	5. CONSERVATIVE FACTOR	34
		6. LIGHT DURATION	35
		7. SAMPLING RATE	35
WATCH MODE	12	SET MODE (OPERATION MODE)	36
WATCH MAIN SCREEN	13	HISTORY	36
ALT	13	SERIAL NUMBER	36
SHOW DUAL TIME	14	DIVE OPERATION	37
CDT (COUNTDOWN TIMER)	14	INITIATING A DIVE	38
CHRONOGRAPH	15	NO DECOMPRESSION DIVE MAIN	38
DAILY ALARM	16	DIVE ALT 1	38
SET TIME MENU	17	DIVE ALT 2	39
1. Date Format	17	DEEP STOP PREVIEW	39
2. Hour Format	17	DEEP STOP MAIN	39
3. Default Time	18	SAFETY STOP MAIN	39
4. Alternate Time	18	SURFACING	40
5. Time Of Day	18	GAS SWITCHES	41
6. Date	19	OVERVIEW	41
DIVE FEATURES	20	COMPLICATIONS	42
DTR (DIVE TIME REMAINING)	21	DECOMPRESSION	42
NO DECOMPRESSION	21	DECOMPRESSION ENTRY	42
O2 MIN (OXYGEN TIME REMAINING)	21	DECOMPRESSION STOP MAIN	42
BAR GRAPHS	21	CONDITIONAL VIOLATION (CV)	43
VARI BAR GRAPH	22	DELAYED VIOLATION 1 (DV 1)	43
TLBG (TISSUE LOADING BAR GRAPH)	22	DELAYED VIOLATION 2 (DV 2)	44
ALGORITHM	22	DELAYED VIOLATION 3 (DV 3)	44
CONSERVATIVE FACTOR	22	VIOLATION GAUGE MODE DURING A DIVE	44
DS (DEEP STOP)	22	VIOLATION GAUGE MODE ON THE SURFACE	45
SS (SAFETY STOP)	23	HIGH PO ₂	45
LOW BATTERY WHILE ON THE SURFACE	23	Warning	45
LOW BATTERY DURING A DIVE	23	Alarm	45
AUDIBLE/VISUAL ALARM	24	PO ₂ During Decompression	46
		HIGH O ₂ SAT (OXYGEN SATURATION)	46
DIVE SURFACE MODE	25	Warning	46
ON THE SURFACE BEFORE A DIVE	26	Alarm	46
ALT 1 (LAST DIVE)	26	Warning During Decompression	46
ALT 2	26	Alarm During Decompression	47
ALT 3	27	Alarm On Surface	47
FLY/DESAT	27		
PLAN	27		
LOG	28		
SET FO ₂ (GAS MIX)	29		
SET ALARMS	30		
1. Audible Alarm	30		
2. DEPTH ALARM	30		
3. EDT (Elapsed Dive Time) Alarm	31		

GAUGE MODE	48
ON THE SURFACE BEFORE A DIVE	49
INITIATING A DIVE	49
GAUGE DIVE MAIN	50
GAUGE DIVE ALT 1	50
GAUGE DIVE ALT 2	50
RUN TIMER	50
DELAYED VIOLATION 3 (DV3)	51
FREE MODE	52
FREE DIVE MODE DETAILS	53
ON THE SURFACE BEFORE A DIVE	54
ALT 1	54
ALT 2	54
COUNTDOWN TIMER (CDT)	55
SET ALARMS	55
1. Elapsed Dive Time Alarm	56
2. Depth Alarms 1-3	56
SET MODE (OPERATION MODE)	56
INITIATING A DIVE	57
FREE DIVE MAIN	57
FREE DIVE ALT 1	57
FREE DIVE ALT 2	58
HIGH NITROGEN ALARMS	58
REFERENCE	59
PC INTERFACE	60
CARE AND CLEANING	61
SERVICE	61
BATTERY REPLACEMENT	62
ALTITUDE SENSING AND ADJUSTMENT	64
TECHNICAL DATA	65
NO DECOMPRESSION TIME LIMITS	66
OXYGEN EXPOSURE LIMITS	67
ALTITUDE LEVELS	67
SPECIFICATIONS	68
ABBREVIATIONS/TERMS	70

GETTING STARTED

BASICS

Welcome to your new i200. The i200 is an easy to use dive computer utilizing a four button interface. Divers may choose between four modes of functionality consisting of Watch, Dive, Gauge, and Free Mode. Though the i200 is easy to use, you will get the most out of your new i200 if you take some time to familiarize yourself with its displays and operation. Information has been organized into easy to follow sections to aid you in learning all you need to know. There is also a glossary at the end of this guide for any terms that may sound unfamiliar.

INITIAL ACTIVATION

i200 Dive Computers are placed in a Deep Sleep mode prior to being shipped from the factory. The intent is to extend storage life of the Battery for up to 7 years, before the unit is initially placed into service.

In this mode, Date and Time are updated as they normally would be. However, they are not displayed. Upon waking the i200 up, the correct Date and USA Pacific Time will be displayed and it will be ready to operate with full functions.

To wake the i200 up from Deep Sleep mode, simultaneously depress the upper/right (SELECT) and lower/left (ADV) buttons for 3 seconds until the display comes ON displaying the Watch Main Time screen, then release them.

NOTE: Once the i200 is brought out of the Deep Sleep mode, it can only be placed back into it by the factory.

DISPLAY ICONS

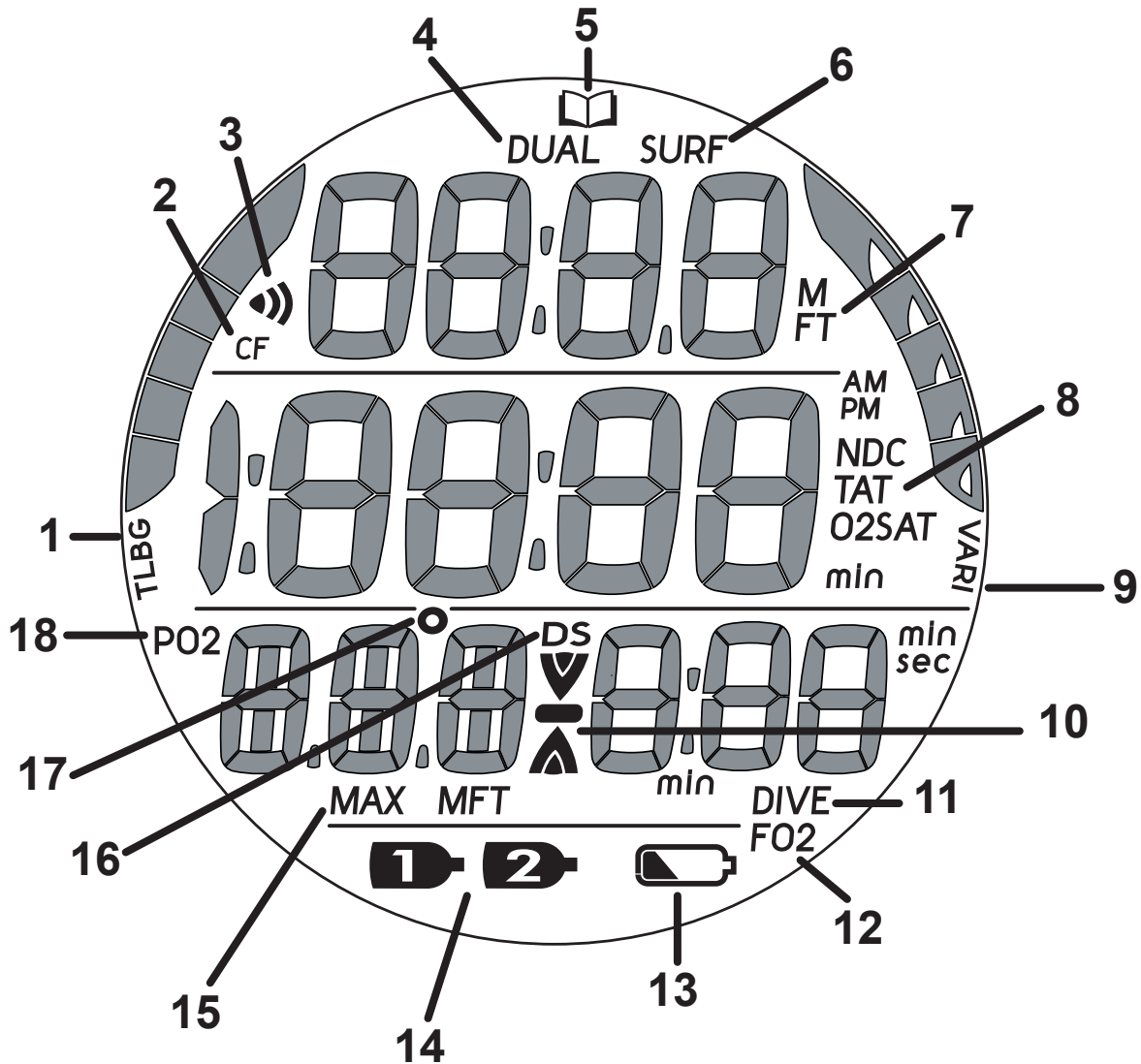

1	Tissue Loading Bar Graph
2	Conservative Factor
3	Daily Alarm Set
4	Time ID
5	Logbook
6	Surface
7	Depth ID (units)
8	Time ID
9	Variable Ascent Rate

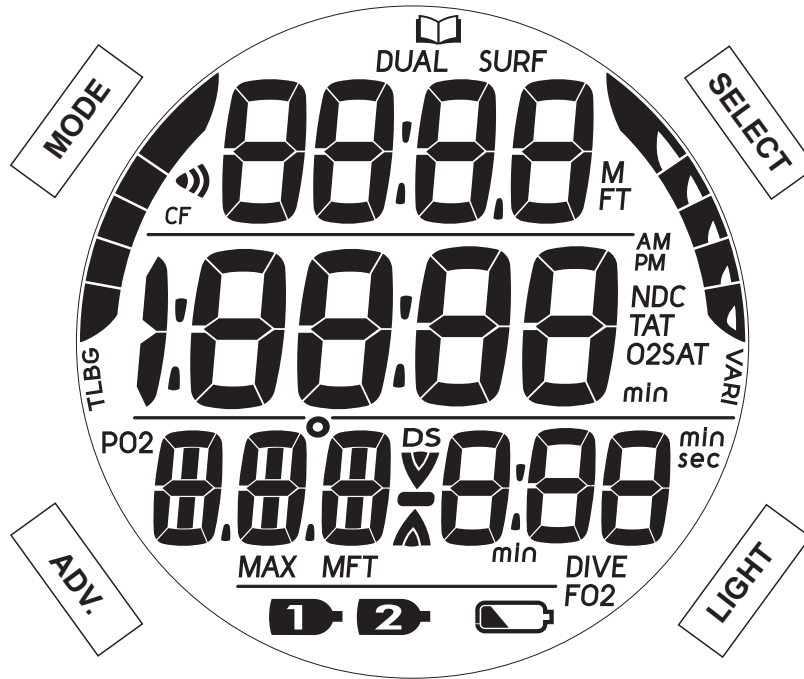

10	Descend, Ascend, or Stop
11	Dive Time or #
12	Fraction of Oxygen
13	Low Battery
14	Gas #
15	Value is Max Depth
16	Deep Stop
17	Temperature
18	Partial Pressure of Oxygen













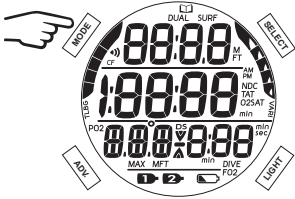

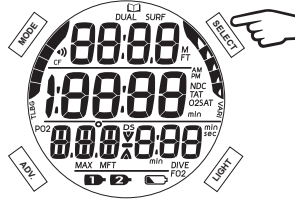
BUTTONS

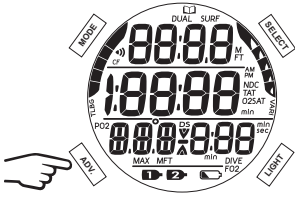

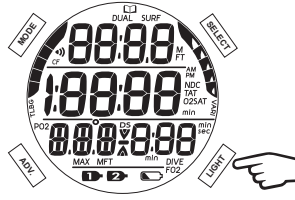
The i200 utilizes 4 control buttons called the MODE, SELECT, ADV. (Advance) and, LIGHT buttons. They allow you to select mode options and access specific information. They are also used to enter settings, activate the backlight, and acknowledge the audible alarm.

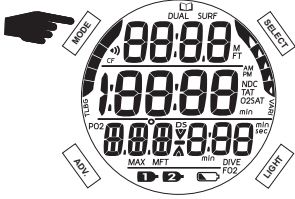
Pressing different combinations of these buttons will navigate through different menus and options of the i200. The symbols in the table below will illustrate how to proceed through the menus.

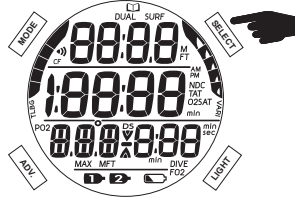
SYMBOL	MEANING
	<p>PRESS BUTTON LESS THAN 2 SECONDS</p>
	<p>HOLD BUTTON GREATER THAN 2 SECONDS</p>

BUTTON FUNCTIONS

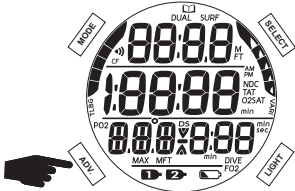
ACTION	BUTTON	FUNCTION
		<ul style="list-style-type: none"> • to move backward through the Main Menu • to decrease a setting
		<ul style="list-style-type: none"> • to select/save an option or setting
		<ul style="list-style-type: none"> • to access Alt screens • to advance through selections • to toggle or change setpoints • to increase a setting
		<ul style="list-style-type: none"> • to activate the backlight
		<ul style="list-style-type: none"> • to switch between Watch Mode and the active diving mode, while on the Main screen • to exit a menu directly to the Main screen
		<ul style="list-style-type: none"> • to exit or step back to the previous screen or setting

ACTION	BUTTON	FUNCTION
		<ul style="list-style-type: none"> • to scroll or increase a setting value at a faster rate • to reset chronograph (Watch Mode)

WATCH MODE

WATCH MAIN SCREEN

The Watch Main screen is the default screen of the i200. The i200 allows you to choose between displaying one or two time zones. This is useful when wearing the i200 as your primary timepiece while travelling.

NOTE: The terms HOME and AWAY are intended to represent two different time zones, your local and destination time zones respectively. Either time can be set as the Default Time. If DUAL time is set ON, the time zone that is not set as the Default Time will display in the top section of the screen.

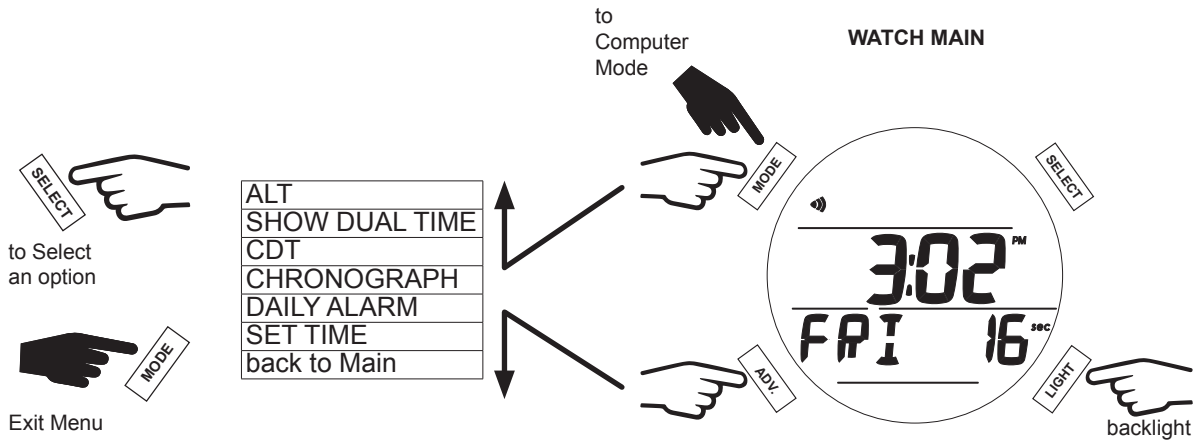
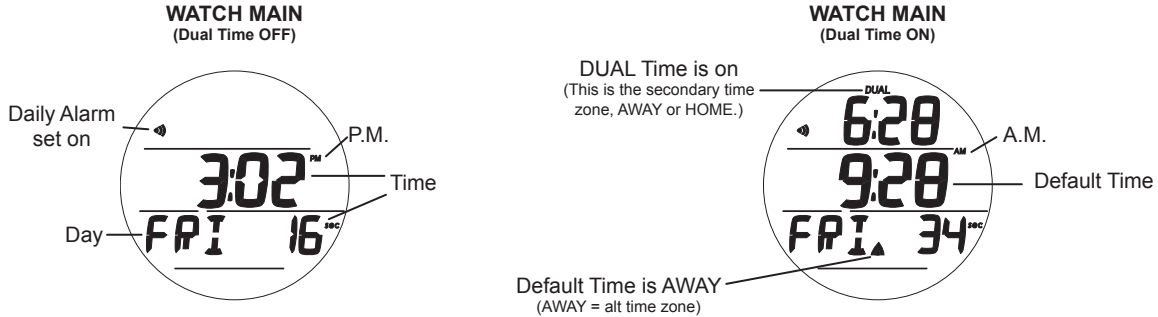

ALT

ALT displays the date, temperature, and elevation.

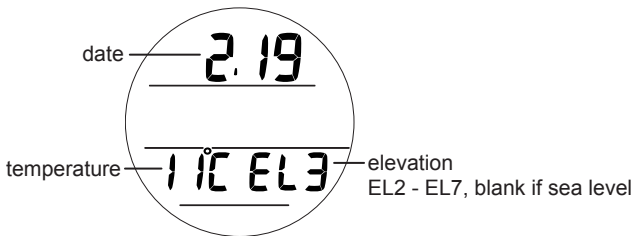

SHOW DUAL TIME

This setting allows you to choose whether or not to show dual time zones, both HOME and AWAY, on the Watch Main screen. If you select yes, the secondary time reading will display at the top on the Watch Main screen.

NOTE: If the Set Dual Time in the Set Time menu is set to OFF (00 hour difference), the secondary time will not be displayed on the Watch Main screen.

SHOW DUAL TIME LEAD-IN



SHOW DUAL OFF/ON

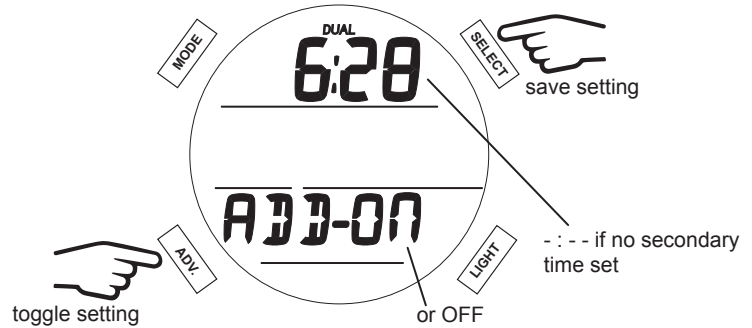

CDT (Countdown Timer)

This feature allows you to program a countdown timer with audible alarm. The initial options are OFF or SET. To set the timer you must save an hour value then the minute value. You may choose a value between 0:01 and 23:59. Once a countdown time is set, the ON selection becomes available in Set CDT screen. If On is selected, the CDT will run in the background until it counts down to 0:00, or it is set OFF. When a set Countdown time reaches 0:00, the Audible Alarm will sound. During which time the graphic CDT will flash on the Watch Main screen.

NOTE: Switching to Dive, Gauge, Free modes, or initiating a dive will terminate the CDT and revert the CDT setting to OFF.

CDT LEAD-IN

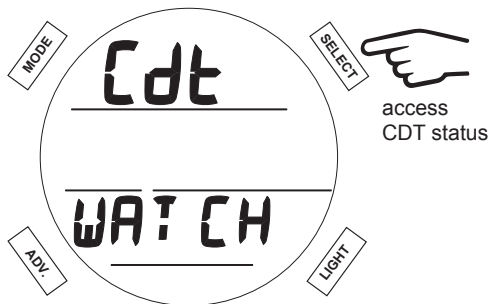

CDT STATUS

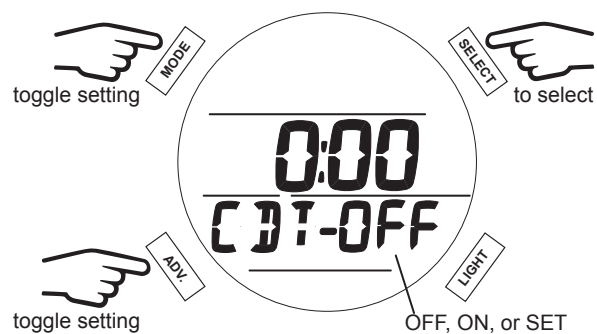

SET CDT

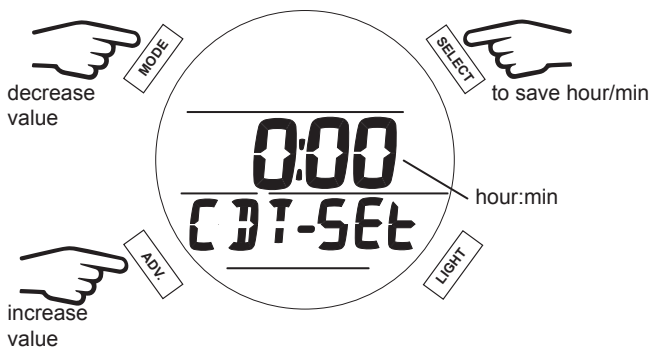

WATCH MAIN
(during CDT Alarm)



CHRONOGRAPH

The chronograph has a 9 lap memory. After 9, subsequent laps will be recorded and the earliest lap discarded. If the Chrono continues to run and reaches 9:59:59.99, it will stop and record that as a Lap. Subsequent presses of SELECT then have no effect.

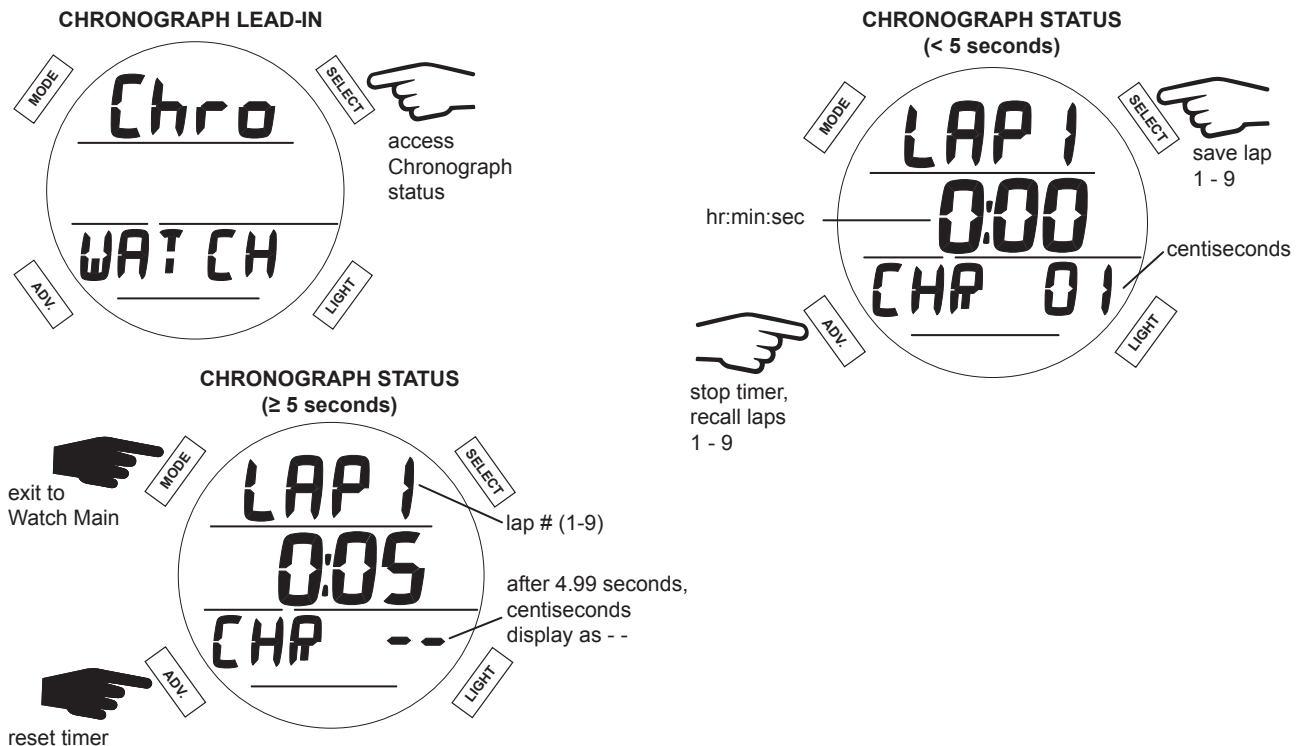

NOTE: If the Chrono continues to run and reaches 9:59:59.99, it will stop and record that as a Lap. Subsequent presses of SELECT then have no effect.

NOTE: Once the Chronograph has been set and started, it will remain on and displayed (or continue to run in the background) while on the surface until reset by the user. Upon descending to 1.5 M/5 FT (i.e., entry into a Dive, Gauge, or Free Mode dive), operation will be terminated and the counter will reset to 0:00:00.00 (hr:min:sec.centisecond).

DAILY ALARM

When set ON, the Daily Alarm, that runs in the background, will sound the audible alarm at the time set every day when that time equals the Watch Default Time selected. The Audible will not sound while operating in dive computer modes. Operation reverts back to Watch Main after selection of ON or OFF options.

DAILY ALARM LEAD-IN

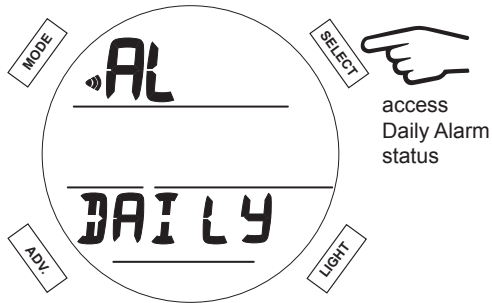

DAILY ALARM STATUS

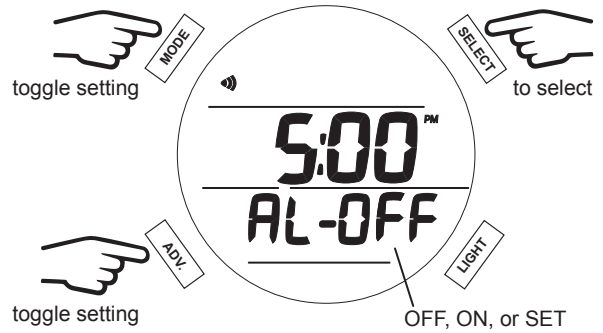

SET DAILY ALARM

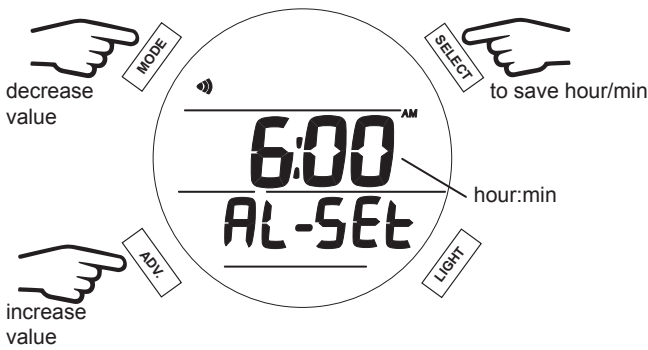

SET TIME MENU

Selecting Set Time accesses a sub menu. Within this menu you can set the time settings: Date Format, Hour Format, Default Time, Alternate Time, Time of Day, and Date.

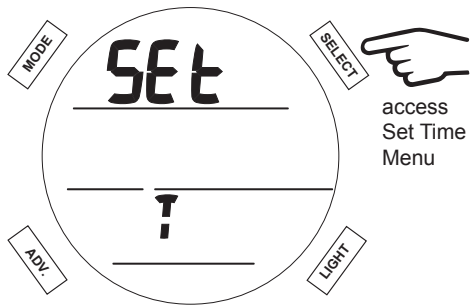

1. Date Format

Choose your preferred date format.

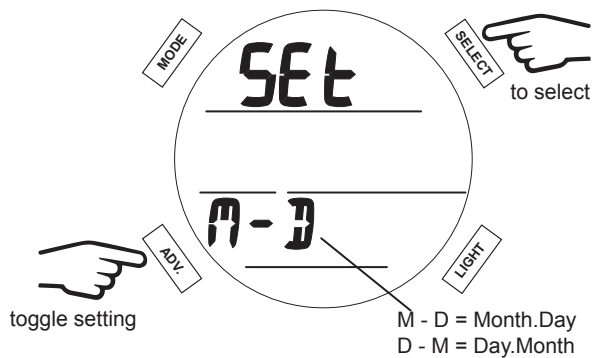

2. Hour Format

Choose your preferred hour format.

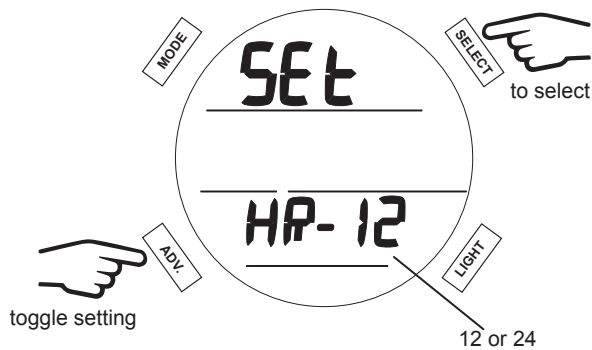

3. Default Time

This setting allows you to choose the time HOME or AWAY that displays as the default on the Watch Main.

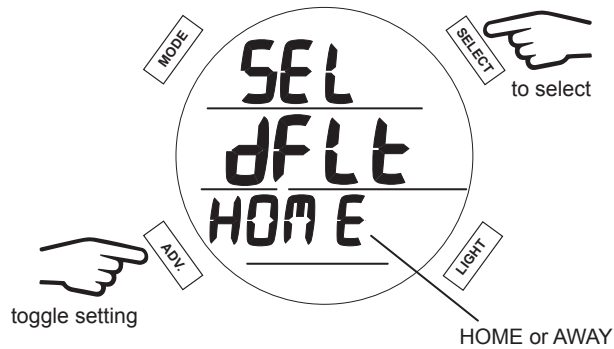

4. Alternate Time

Alternate Time allows you to set another time zone that is referred to as AWAY Time. Selections available are OFF or -23 - +23 hour difference.

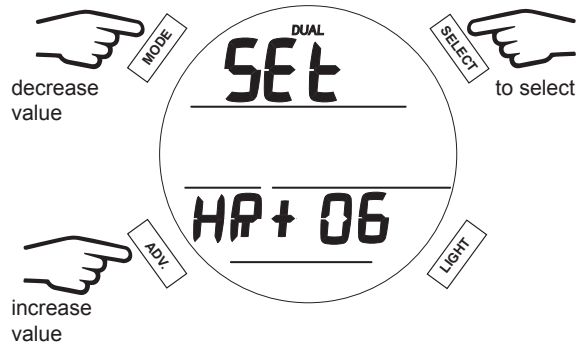

5. Time Of Day

Set the Default (Home or Away) time. Set hours then minutes.

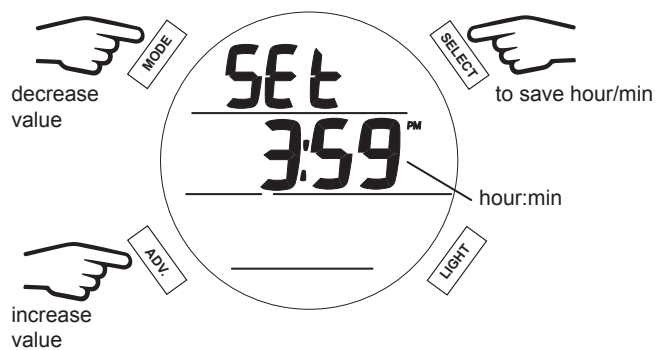

6. Date

Set the year, month, and day in order. The corresponding digit will flash, allowing it to be set.



DIVE FEATURES

DTR (DIVE TIME REMAINING)

The i200 constantly monitors No Decompression status and O2 Accumulation, and will display whichever time is the least amount available as DTR on the No Decompression Dive Main screen. The Time being displayed will be identified by the NDC min (no decompression time) or O2 min icons.

NO DECOMPRESSION

No Decompression is the maximum amount of time that you can stay at your present depth before entering decompression. It is calculated based on the amount of nitrogen absorbed by hypothetical tissue compartments. The rates each of these compartments absorb and release nitrogen is mathematically modeled and compared against a maximum allowable nitrogen level.

Whichever compartment is closest to this maximum level is the controlling compartment for that depth. Its resulting value NDC (no decompression) will be displayed. It will also be displayed graphically as the TLBG Bar Graph, see Bar Graphs below.

As you ascend, the TLBG Bar Graph segments will recede as control shifts to slower compartments. This is a feature of the decompression model that is the basis for multilevel diving, one of the most important advantages that Aqua Lung dive computers offer.

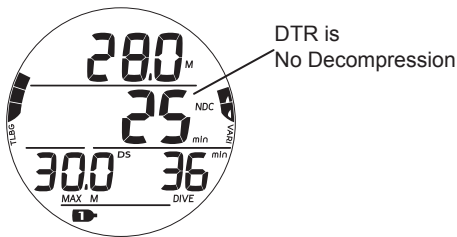

O2 MIN (OXYGEN TIME REMAINING)

When set for nitrox operation, O2 SAT (Oxygen Saturation) during a dive is displayed on an ALT screen as a percentage of allowed saturation identified by the O2 SAT icon. The limit for O2 SAT (100%) is set at 300 OTU (Oxygen Tolerance Units) per dive or 24 hour period. See the chart at the back of this manual for specific times and allowances. O2 SAT and O2 min values are inversely related; as the O2 SAT value increases the O2 min value decreases.

When the O2 min value becomes less than the No Decompression calculations for the dive, DTR (Dive Time Remaining) will be controlled by O2 SAT and the O2 min value will be displayed as the DTR on the Dive Main screen, identified by the O2 min icon.

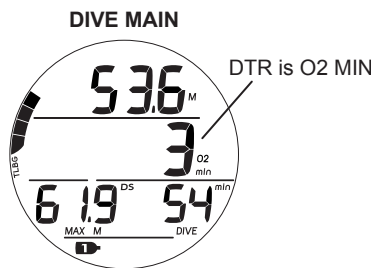
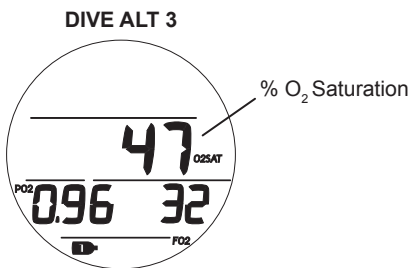

BAR GRAPHS

The i200 features two specific bar graphs.

1. The one on the left represents nitrogen loading. It is referred to as the TLBG (Tissue Loading Bar Graph).
2. The one on the right represents ascent rate. It is referred to as the VARI Bar Graph.

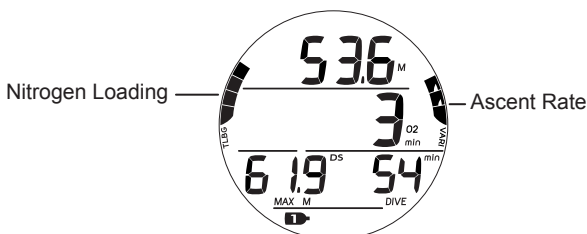

VARI BAR GRAPH

The VARI Bar Graph provides a visual representation of ascent speed (i.e., an ascent speedometer). When the ascent is faster than the recommended 9 mpm (30 fpm), all segments flash until the ascent is slowed.

# OF SEGMENTS	ASCENT RATE, MPM (FPM)
0	0 - 3 (0 - 10)
1	3.1 - 4.5 (11 - 15)
2	4.6 - 6 (16 - 20)
3	6.1 - 7.5 (21 - 25)
4	7.6 - 9 (26 - 30)
5	> 9 (> 30)

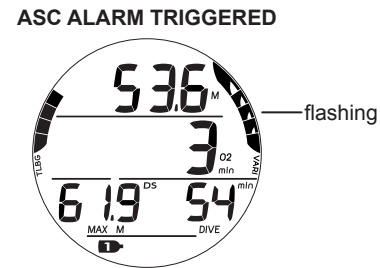

TLBG (TISSUE LOADING BAR GRAPH)

The TLBG represents your relative No Decompression or Decompression status. The first four segments represent No Decompression status and the fifth indicates a Decompression condition. As your Depth and Elapsed Dive Time increase segments are added. As you ascend segments recede, indicating that additional No Decompression time is available. The i200 monitors multiple different nitrogen compartments simultaneously and the TLBG displays the one that is in control of your dive at any given time.

ALGORITHM

The i200 utilizes the Z+ algorithm to calculate nitrogen tissue loading. Performance is based on Bühlmann ZHL-16C algorithm model. To create even greater margins of safety with respect to decompression, a Conservative Factor as well as No Decompression Deep and Safety Stops can be included for No Decompression dives.

CONSERVATIVE FACTOR

When the CF is set On, the dive time remaining, No Decompression/O2 MIN, which are based on the algorithm and used for N2/O2 calculations and displays relating to Plan Mode, will be reduced to the values available at the altitude level that is 3,000 ft (915 m) higher than the actual altitude at activation. Refer to the charts in the back of this manual for dive times.

DS (DEEP STOP)

When the DS selection is set ON, it will trigger after descending deeper than 24 m (80 ft). The i200 then calculates (continually updating) a Stop Depth equal to 1/2 the Max Depth.

NOTE: The DS feature only works in DIVE Mode while within No Decompression times.

- While 3 m (10 ft) deeper than the calculated DS, you will be able to access a DS Preview screen that will display the current calculated Deep Stop Depth/Time.
- Upon initial ascent to within 3 m (10 ft) below the calculated Stop Depth, a DS screen displaying a Stop Depth at 1/2 the Max Depth will appear with a countdown timer beginning at 2:00 (min:sec) and counting down to 0:00. If you descend 3 m (10 ft) below, or ascend 3 m (10 ft) above, the calculated Stop Depth for 10 seconds during the countdown, the No Decompression Main will replace the DS Main display and the DS feature will be disabled for the remainder of that dive. There is no Penalty if the DS is ignored.
- In the event that you enter Decompression, exceed 57 m (190 ft), or a High O2 SAT (Oxygen Saturation) condition, ≥ 80%, occurs, the DS will be disabled for the remainder of that dive.
- The DS is disabled during a High PO₂ Alarm condition, ≥ set point.

SS (SAFETY STOP)

Upon ascent to within 1.5 m (5 ft) deeper than the SS depth set for 1 second on a No Decompression dive in which Depth exceeded 9 m (30 ft) for 1 second, a beep will sound and a SS at the depth set will appear on the Dive Main display with a countdown beginning at the SS time set and counting down to 0:00.

- If the SS was set for OFF, the display will not appear.
- In the event that you descend 3 m (10 ft) deeper than the Stop Depth for 10 seconds during the countdown, or the countdown reaches 0:00, the No Decompression Main screen will replace the SS Main screen which will reappear upon ascent to within 1.5 m (5 ft) deeper than the Safety Stop depth set for 1 second.
- In the event that you enter Decompression during the dive, complete the Decompression obligation, then descend below 9 m (30 ft); the SS Main will appear again upon ascent to within 1.5 m (5 ft) deeper than the SS depth set for 1 second.
- If the diver ascends to within 0.91 m (3 ft) from the surface for 10 seconds, the SS is to be canceled.
- There is no penalty if you surface prior to completing the SS or choose to ignore it.

LOW BATTERY WHILE ON THE SURFACE

Warning Level

- The i200 functions continue but the backlight is disabled.
- The Battery icon appears solid.

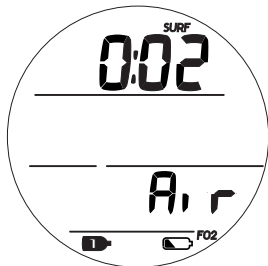

Alarm Level

- If in Dive Computer mode, the battery icon flashes for 5 seconds and operation reverts to Watch Time with the icon flashing until the Battery is changed or voltage cannot sustain operation.

⚠ WARNING: Change the battery before diving if your i200 indicates the Battery Low Warning or Alarm.

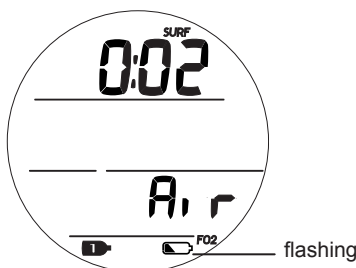

LOW BATTERY DURING A DIVE

Warning Level

- The i200 functions continue but the backlight is disabled.
- The battery icon appears solid upon entry into Surface Mode.

Alarm Level

- The i200 functions continue but the backlight is disabled.
- Upon entry into Surface Mode, the Battery icon (shell only with no inner bar) flashes then operation reverts to Watch Time.

AUDIBLE/VISUAL ALARM

While operating in Dive or Gauge Mode, the audible alarm will emit 1 beep per second for 10 seconds when alarms strike, unless it is set to Off. During that time, the audible alarm can be acknowledged and silenced by pressing the SELECT button.

An LED warning light, on the side of the housing, is synchronized with the audible alarm and flashes as the audible alarm sounds. It will turn off when the alarm is silenced. The audible and LED alarms will not be active if the audible alarm is set to OFF (a Set Alarms setting).

Free Dive Modes have their own alarms which emit multiple beeps multiple times which cannot be acknowledged or set to OFF.

Events that emit (10) beeps >> each sound for ½ sec with ½ sec silence between beeps:

- Watch Daily Alarm.
- Watch CDT Alarm.
- DIVE, GAUGE - Ascent Rate too fast.
- DIVE, GAUGE - Depth Alarm.
- DIVE, GAUGE - Elapsed Dive Time Alarm.
- DIVE - Dive Time Remaining Alarm.
- DIVE - Tissue Loading Bar Graph Alarm.
- DIVE - entry into Decompression.
- DIVE - Conditional Violation.
- DIVE - Delayed Violations 1, 2.
- DIVE, GAUGE - Delayed Violation 3.
- DIVE, GAUGE - entry into Violation Gauge Mode.
- DIVE - PO2 Warning and Alarm.
- DIVE - O2 Warning and Alarm.
- DIVE - Gas Switch Alarm.

Events that emit (3) short beeps:

- FREE - CDT Alarm.
- FREE - Tissue Loading Bar Graph Alarm.
- FREE - Violation, entry into Decompression.
- FREE - DA1 to DA3 Alarms.

DIVE SURFACE MODE

ON THE SURFACE BEFORE A DIVE

The Dive Main screen will display the SURF (Surface Time) and the selected FO₂ of the breathing gas. The surface time displayed is the time since activation or the surface interval after a dive.

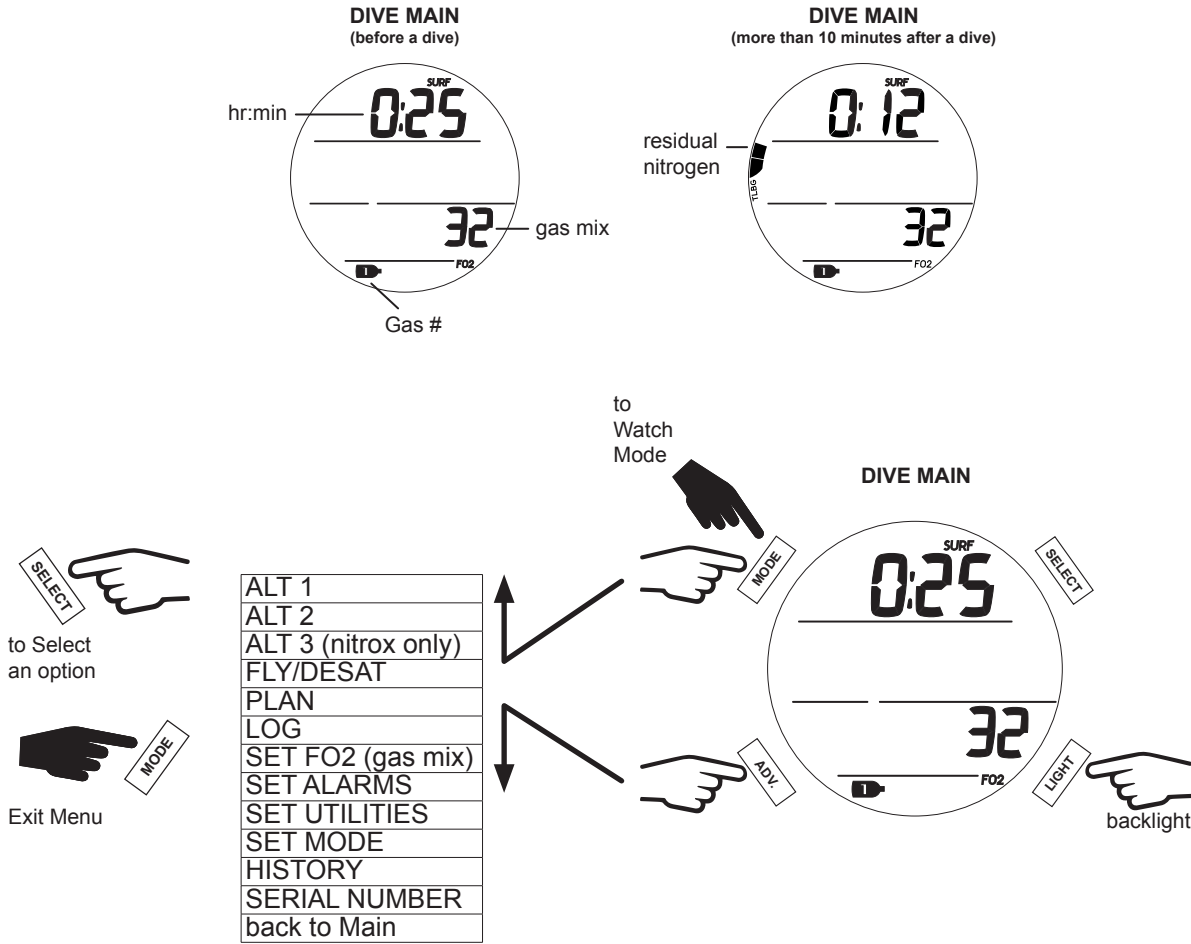

ALT 1 (LAST DIVE)

The ALT 1 screen displays essential data from the last dive. If there has been no dive within the current activation cycle, the dive number will display zero and dashes for the max depth and elapsed dive time will be displayed.

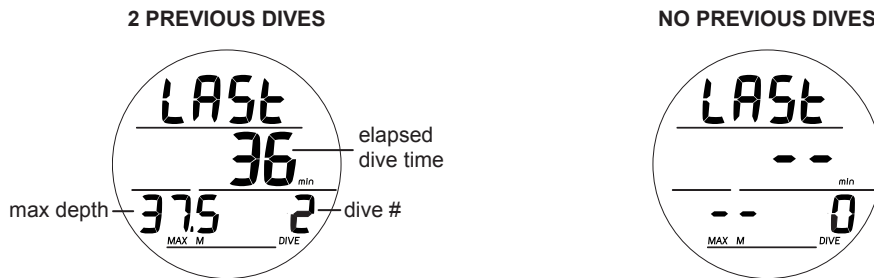

ALT 2

The ALT 2 screen displays time of day, temperature, and current elevation readings.



ALT 3

The ALT 3 screen displays only after a nitrox dive. It displays the current oxygen saturation level, PO₂ Alarm setting, and the current gas mix.

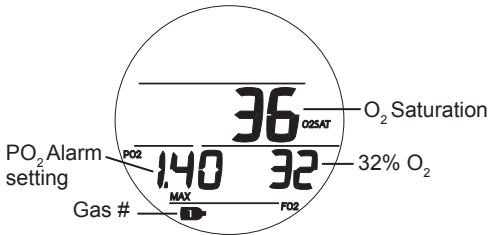

FLY/DESAT

The FLY/DESAT screen displays the Time to Fly and the DESAT (desaturation) countdown. The Time to Fly countdown shall begin counting from 23:50 to 0:00 (hr:min), 10 minutes after surfacing from a dive. The DESAT counter shall provide calculated time for Tissue Desaturation at sea level taking into consideration the CF (Conservative Factor) if it was set on. It shall begin counting down 10 minutes after surfacing from DIVE or FREE dives counting down from a maximum of 23 to 10 (hr only), then 9:59 to 0:00 (hr:min). When the DESAT countdown reaches 0:00 (hr:min), which will generally occur prior to the FLY countdown reaching 0:00 (hr:min), it will remain on the display as 0:00 until the Fly count down reaches 0:00.

NO PREVIOUS DIVES



10 MIN AFTER A DIVE

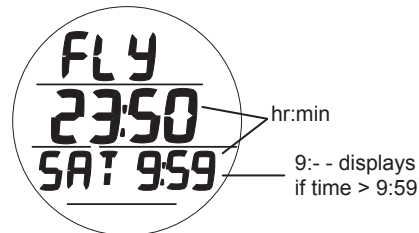

PLAN

This mode calculates dive depth and time limits. To do so, it accounts for any residual nitrogen, oxygen, surface intervals, the programmed gas mix, and PO₂ alarm setting. Either NDC (No Decompression) or O₂ MIN limits are displayed, depending on whether nitrogen or oxygen levels will be the limiting factor. The time limit will display as 1-99 minutes, all times greater than 99 display as 99.

NOTE: Depths exceeding the MOD (Maximum Operating Depth), if nitrox, or that have less than 1 minute allowed dive time will not be displayed.

PLAN LEAD-IN

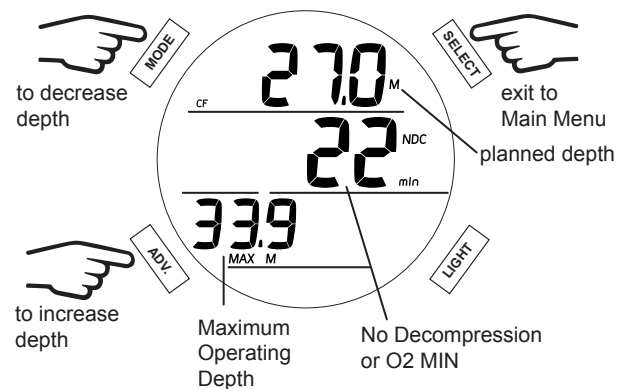
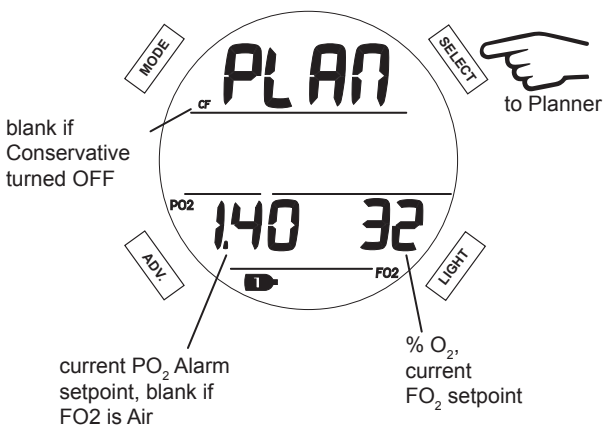

LOG

The log stores Information from the latest 24 Dive and/or Gauge mode dives for viewing.

- If no dives are recorded, the message NONE YET will be displayed.
- After exceeding 24 dives, the most recent dive is stored while the oldest is deleted.
- Dives are numbered from 1 to 24 starting each time a dive is activated in either Dive (or Gauge) mode. After the post dive 24 hour period has elapsed and the unit shuts off, the first dive of the next activation period will be recorded as dive #1.
- In the event that dive time (DIVE MIN) exceeds 999 min, the data at the 999 interval is recorded in the Log upon surfacing of the unit.
- The message GAU (Gauge) or VIO (violation) will display, in the lower left, if applicable on the Log Data 1.

NOTE: New data will automatically overwrite the oldest data in memory when the memory becomes full. If you do not remember to log or download your dives, they will be lost when the memory overwrites. See the PC Download section of this manual for instructions on downloading dives.

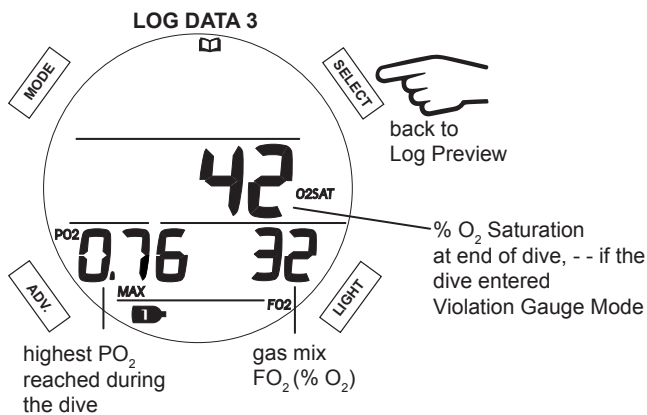
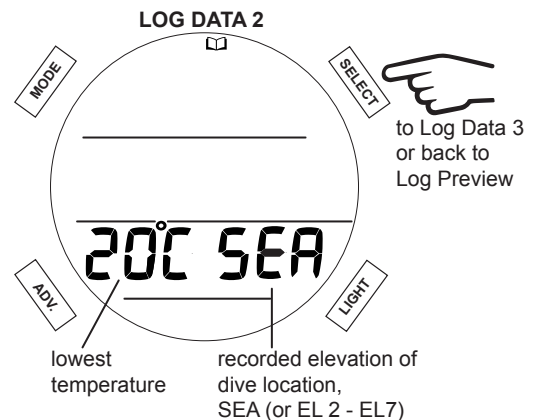
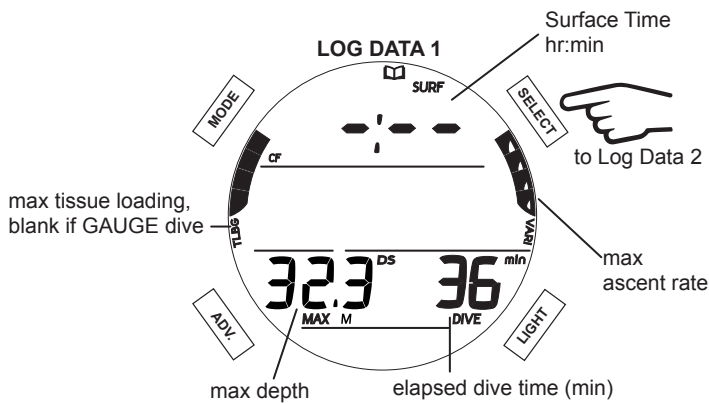
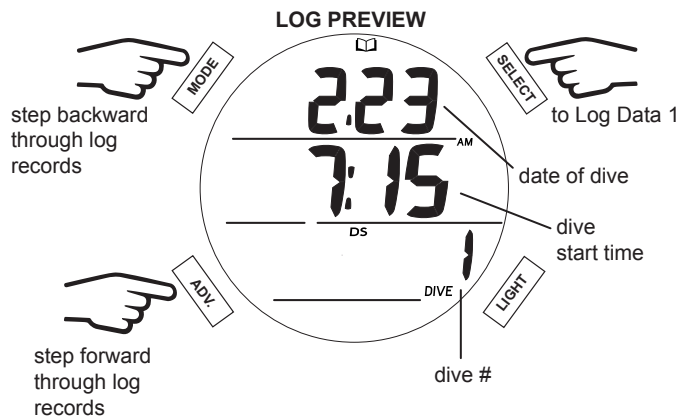
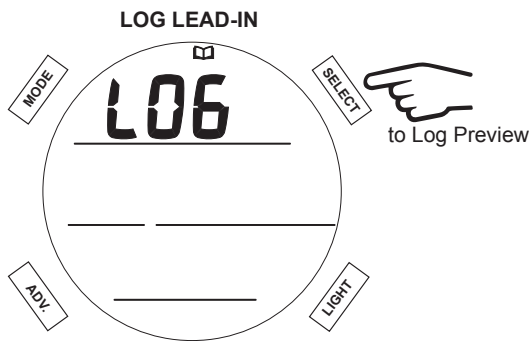

NOTE: Log Data 3 only displays for nitrox dives; it is bypassed if the dive was an air dive.

SET FO₂ (GAS MIX)

Within this submenu you can change the two available gas mixes from air to any nitrox mix between 21 - 100 FO₂ (% O₂). Nitrox mixes are displayed with their corresponding MOD (Maximum Operating Depth) and the current PO₂ Alarm setting for the selected gas. Default settings are FO₂ AIR with no PO₂ alarm value for Gas 1, and OFF for Gas 2. Settings revert to the defaults when 24 hours elapse without conducting a dive. If you set a nitrox mix value for any gas the PO₂ alarm value will default to 1.60 until changed.

NOTE: Once either gas is set for nitrox, the other gas that is set for AIR will automatically be set to 21%. The AIR option will not be displayed as an FO₂ setting until 24 hours elapse after the last dive.

NOTE: When FO₂ is set for AIR, oxygen related data (such as PO₂, % O₂) will not be displayed at any time during the dive, on the surface, or in Plan Mode. Though these oxygen values will be tracked internally for use in any subsequent nitrox dives.

NOTE: Gas 1 cannot be set to OFF.

NOTE: The PO₂ alarm value is set in the Set Alarms Menu.

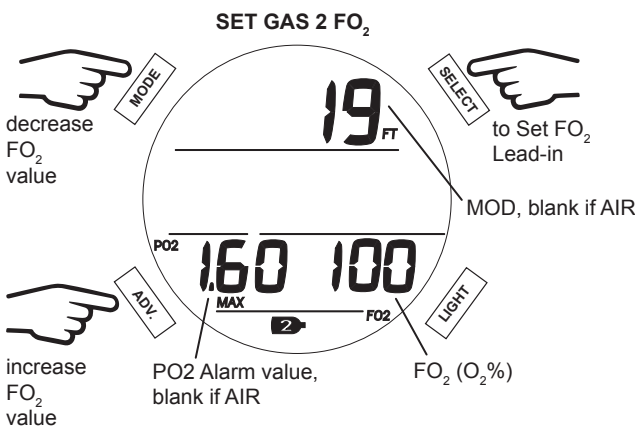
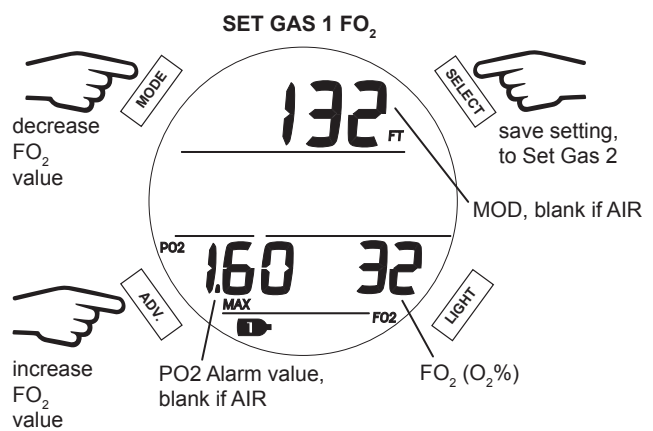
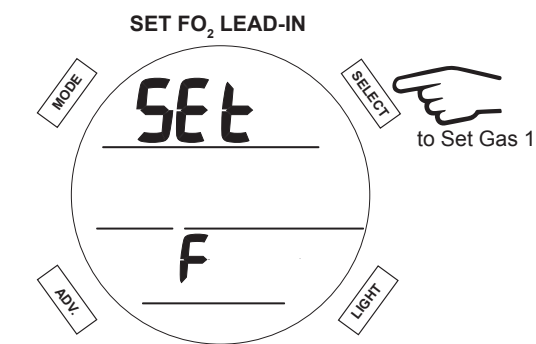

SET ALARMS

Within this submenu you can customize the following six alarm settings.

SET ALARMS LEAD-IN



1. AUDIBLE ALARM

The Audible Alarm feature allows you to set audible alarms ON or OFF.

SET AUDIBLE ALARM

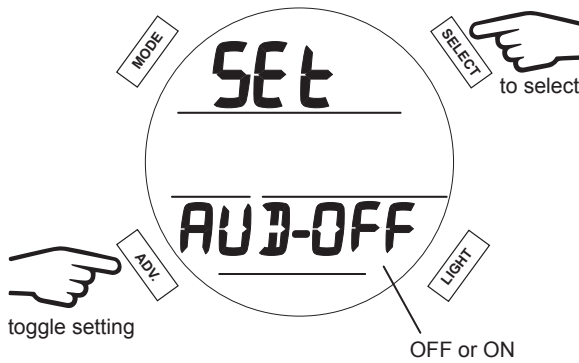

2. DEPTH ALARM

The Depth Alarm feature allows you to set a maximum depth alarm.

SET DEPTH ALARM

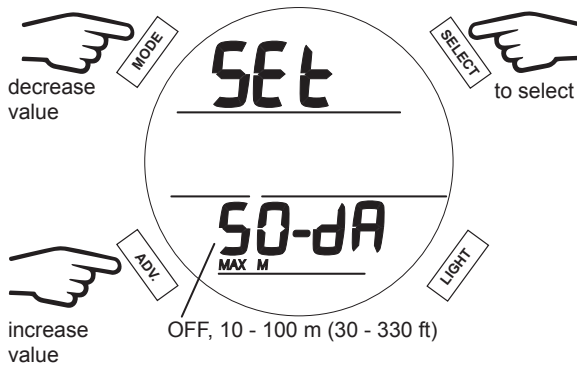

DEPTH ALARM TRIGGERED

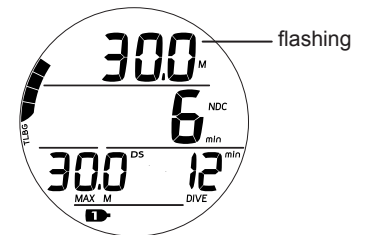

3. EDT (Elapsed Dive Time) Alarm

This feature allows you to set an alarm to go off at a predetermined amount of dive time.

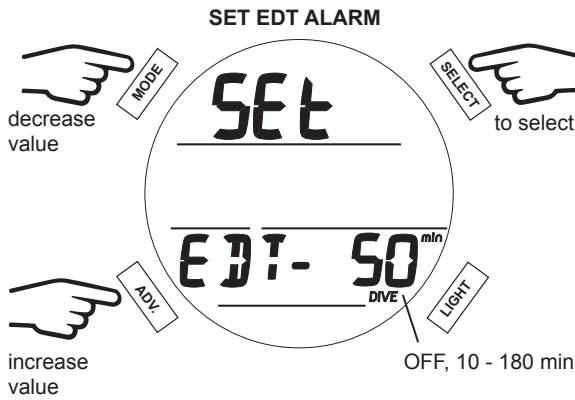

EDT ALARM TRIGGERED

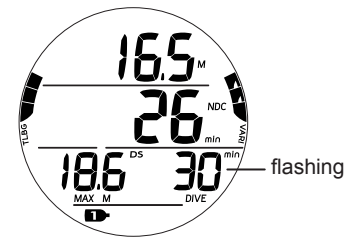

4. TLBG (Tissue Loading Bar Graph) ALARM

This feature allows you to set an alarm to go off at a predetermined number of TLBG segments.

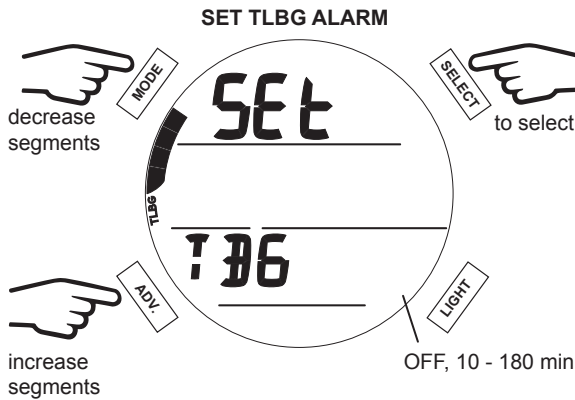

TLBG ALARM TRIGGERED

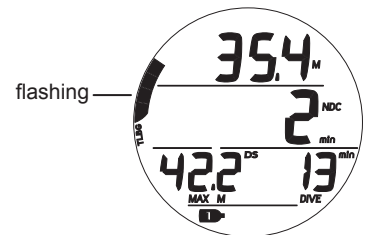

5. DTR (Dive Time Remaining) ALARM

This feature allows you to set an alarm to go off with a designated reserve of dive time remaining.

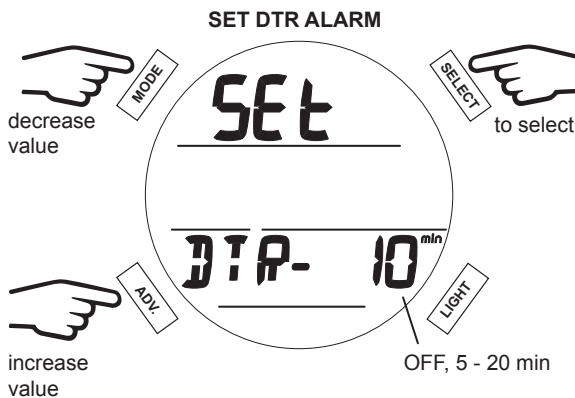

DTR ALARM TRIGGERED

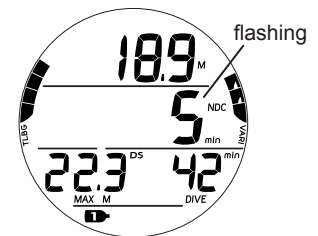

6. PO₂ Alarm

This feature allows you to set an alarm to go off if the PO₂ value of the current gas (1 or 2) exceeds your chosen PO₂ limit.

NOTE: Further details of this alarm function can be found in the High PO₂ section of the Dive Operation chapter.

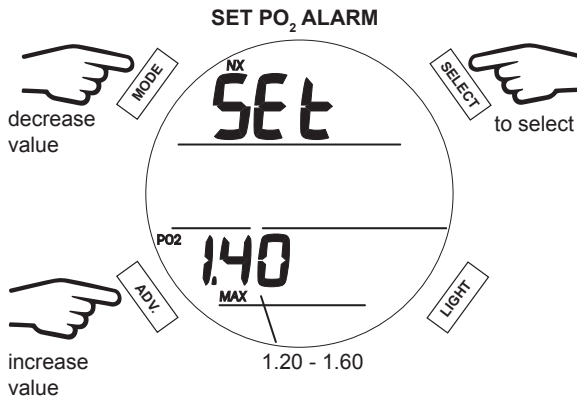

PO₂ ALARM TRIGGERED (during audible alarm)

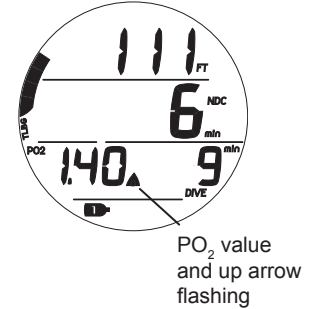

SET UTILITIES

Within the Set Utilities menu you can customize the following seven operational functions.

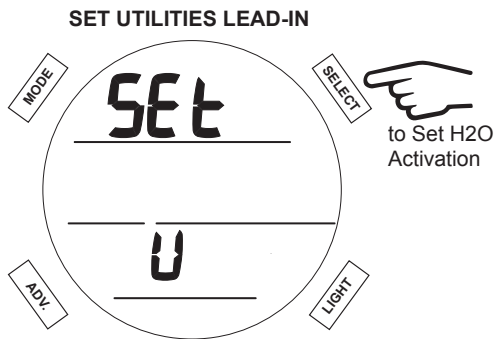

1. H₂O ACTIVATION

The H₂O Activation feature allows you to turn OFF water contact activation.

WARNING: With H₂O Activation turned OFF, you **MUST** remember to manually activate the Dive Mode before any dive.



2. UNITS (IMP/MET)

The Units feature allows you to select whether IMP (imperial) or MET (metric) units of measure will be displayed.

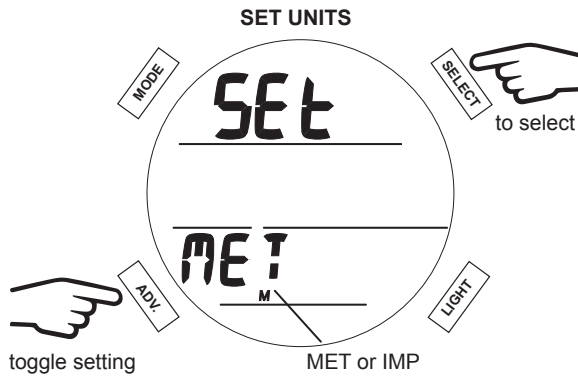

3. DEEP STOP

The Deep Stop feature can be set ON or OFF.

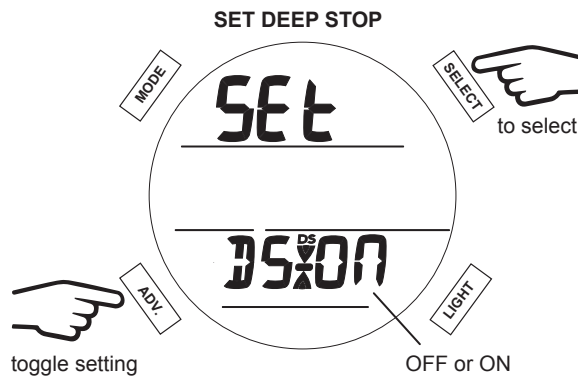

4. SAFETY STOP

The Safety Stop feature can be set ON or OFF. If ON is selected, you may choose from an available 3 or 5 min Safety Stop at depths of 3, 4, 5, or 6 m (10, 15, or 20 ft).

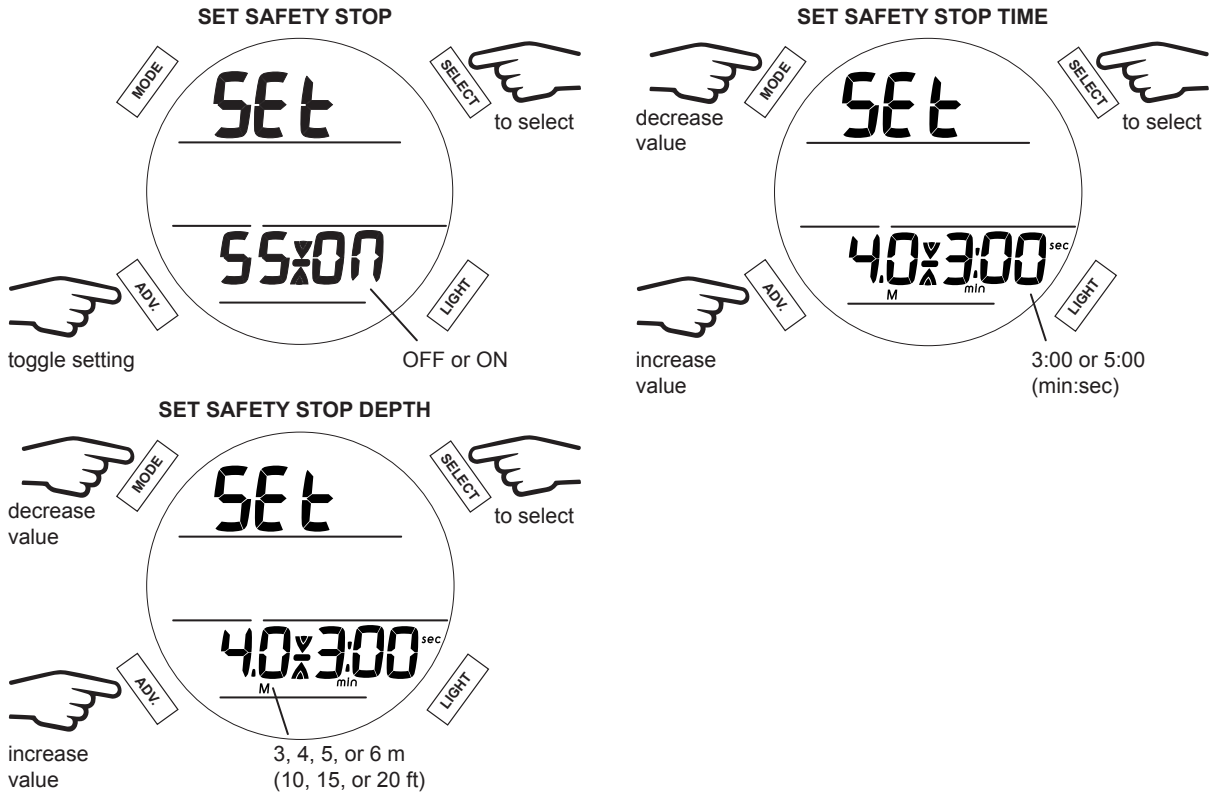

5. CONSERVATIVE FACTOR

The Conservative factor tables feature can be set ON or OFF.

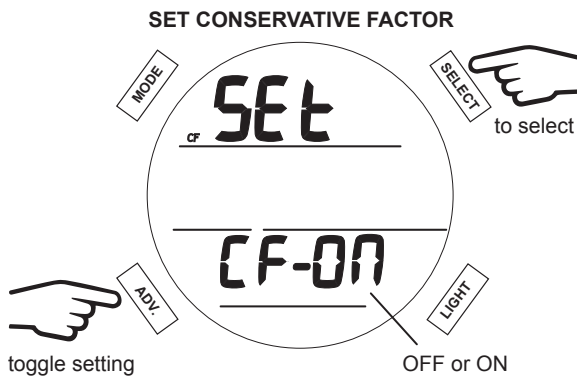

6. LIGHT DURATION

This setting is the duration the backlight stays on after releasing the buttons.

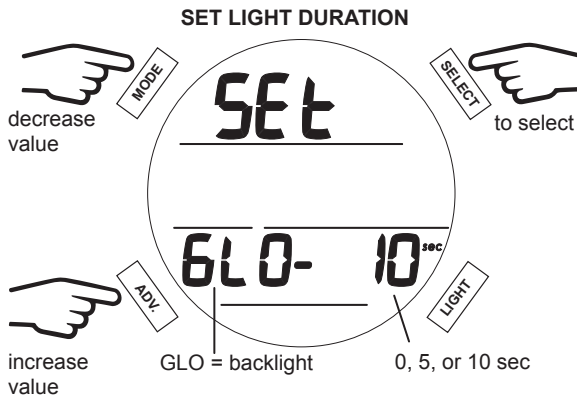

7. SAMPLING RATE

The Sample Rate controls how frequently the i200 stores a data snapshot for PC Download during a dive. Setting options are 2, 15, 30, or 60 second intervals. Shorter intervals will provide a more precise record of your dives.

NOTE: New data will automatically overwrite the oldest data in memory when the memory becomes full. The i200 Log and PC Download data is stored separately in different partitions of the memory. The Log only stores a short summary of each dive. Alternately, the PC Download function stores much larger files for each dive. Depending on the chosen settings and dive durations, it is possible to see dives stored in the i200's onboard Log that have already been overwritten in the PC Download Partition. Choosing a longer Sample Rate interval will consume less memory per dive. Remember to download your dives more frequently if you are using a shorter Sample Rate interval.

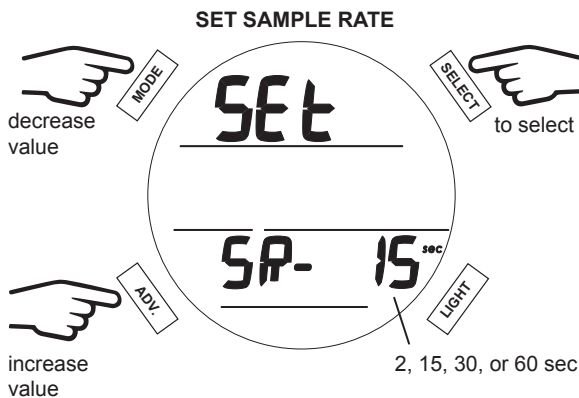

SET MODE (OPERATION MODE)

Set Mode allows you to choose between Dive (standard recreational dive), Gauge, and Free (free diving) modes of operation.

NOTE: Once a dive is conducted in Gauge mode, the i200 shall operate with limited functions without any decompression or oxygen monitoring functions. A 24 hour surface interval shall be required for the unit to operate as a full function dive computer in Dive or Free mode.

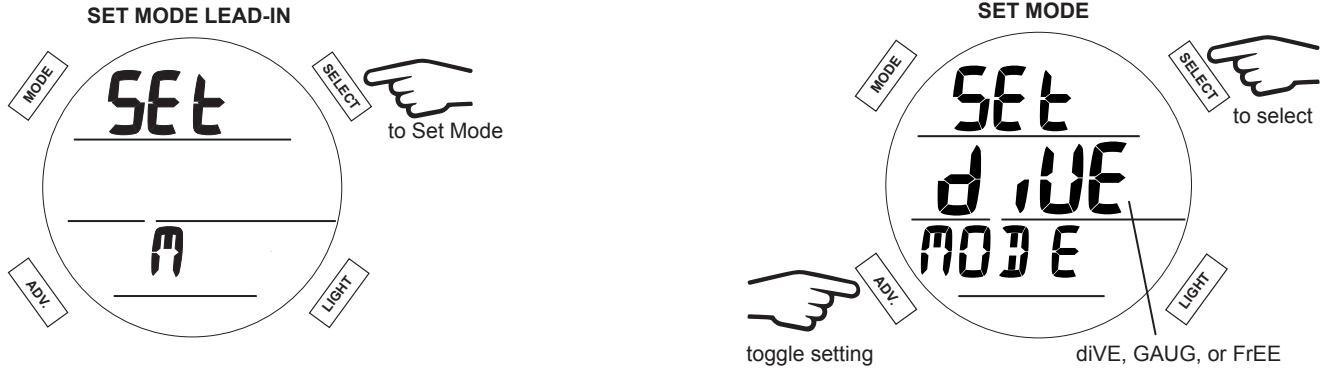

HISTORY

History is a summary of all basic data recorded during Dive and Gauge mode dives.

NOTE: Dives made in Free mode are not shown in History or the Log Mode. Free dive data is only visible using the PC Download software.

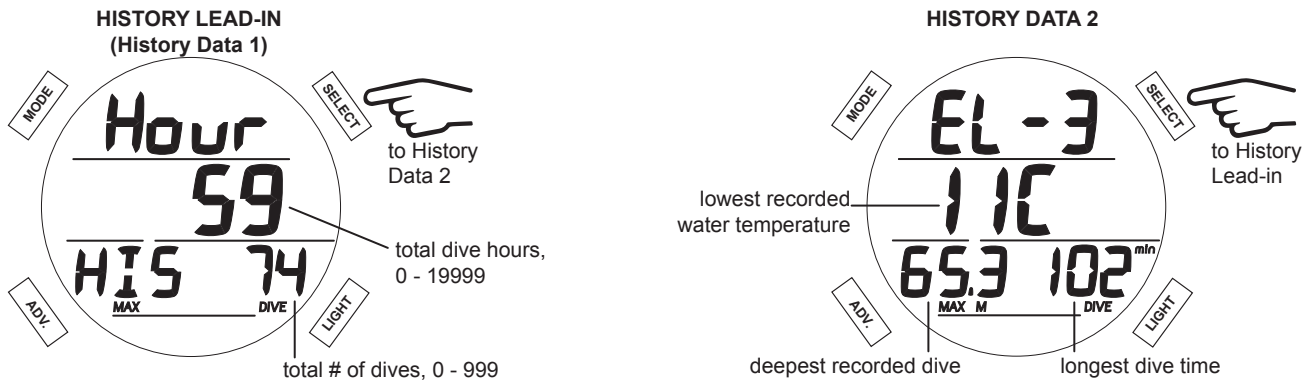

SERIAL NUMBER

Information displayed on the Serial Number screen should be recorded and kept with your sales receipt; it will be required in the event that your i200 requires factory service.

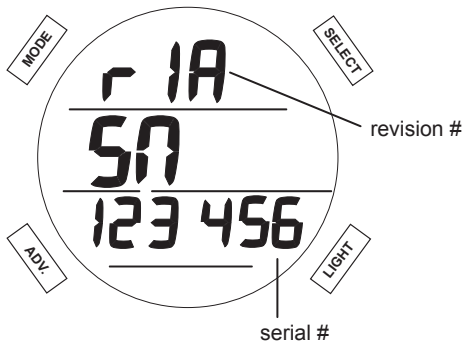

DIVE OPERATION

INITIATING A DIVE

With the i200 in Dive mode, a dive will commence upon descending to 1.5 m (5 ft) for at least 5 seconds. Below is a diagram to help you navigate Dive mode functions.

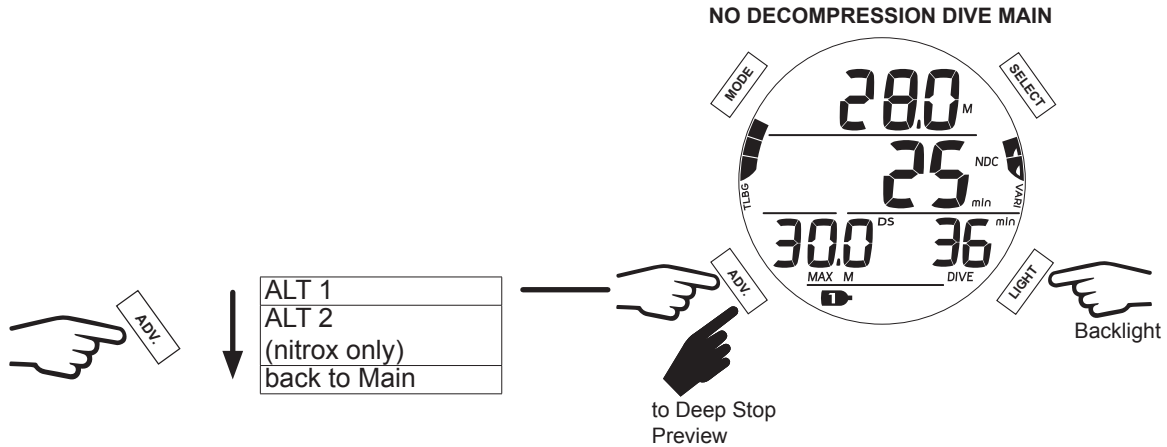

NO DECOMPRESSION DIVE MAIN

From the Main screen you can see all critical dive parameters. During a dive an audible alarm may sound and the priority of information displayed may change. This is to indicate a safety recommendation, warning, or alarm. The following information in this chapter demonstrates and describes an uneventful dive, in terms of safety. Alarms are described in the Complications section of this chapter.

⚠ WARNING: Before diving with the i200 take time to familiarize yourself with both normal and alarm conditions of operation.

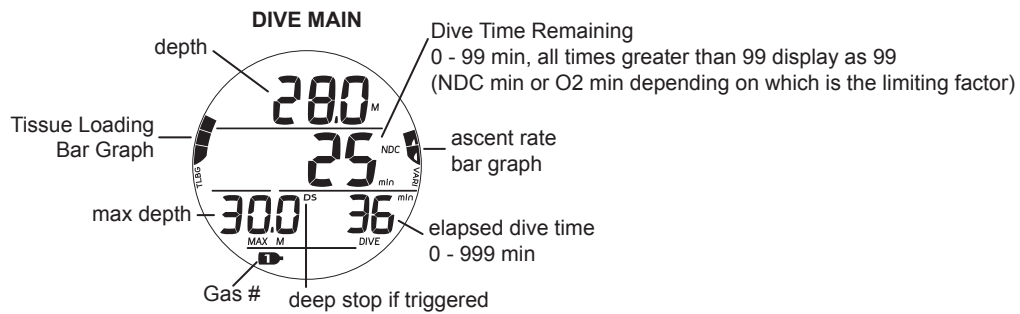

DIVE ALT 1

This screen simply tells you the current time of day and ambient temperature.



DIVE ALT 2

The ALT 2 screen displays information pertaining to nitrox; it is bypassed if the i200 is set for air.

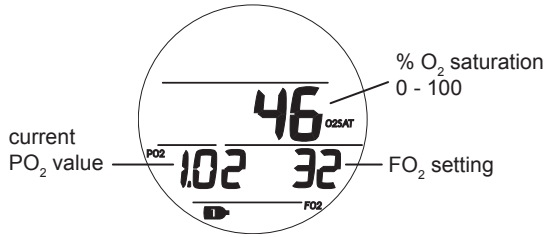

DEEP STOP PREVIEW

If Deep Stop was set to ON in the Utilities Menu, the Deep Stop preview screen is available after exceeding 24 m (80 ft) of depth. The Deep Stop is always at a depth half that of your maximum depth during the dive. This preview screen keeps track of that depth for you.



DEEP STOP MAIN

If triggered, the Deep Stop will activate upon ascending to within 3 m (10 ft) below the calculated Deep Stop depth. The stop time will be displayed and count down to 0:00 as long as you stay within 3 m (10 ft) above or below the stop. While Deep Stop Main is displayed, you may access up to 3 ALT displays by pressing the ADV button to cycle through them. They are similar to the No Decompression Main, Dive ALT 1, and Dive ALT 2 displays, respectively. See Deep Stop in the Dive Features chapter for further details.

NOTE: The i200 does not penalize for a missed Deep Stop.

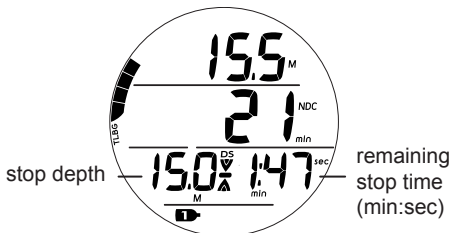

SAFETY STOP MAIN

If triggered, the Safety Stop will activate upon ascent to within 1.5 m (5 ft) deeper than the Safety Stop depth on a No Deco dive. The stop time will then countdown to 0:00. While Safety Stop Main is displayed, you may access up to 3 ALT displays by pressing the ADV button repeatedly. They are similar to the No Deco Main, Dive ALT 1, and Dive ALT 2 displays, respectively. See Safety Stop in the Dive Features chapter for further details.

NOTE: The i200 does not penalize for a missed Safety Stop.

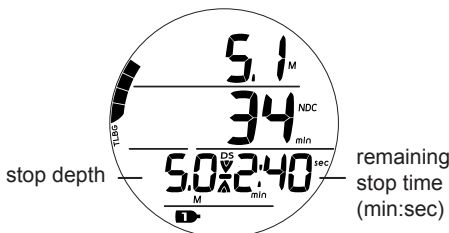

SURFACING

Upon ascending to 0.9 m (3 ft) the i200 transitions to Dive Surface mode.

NOTE: The i200 requires a 10 minute surface interval to record a subsequent dive as a separate dive in the Log. Otherwise, the dives will be combined and recorded as a single dive in the i200 memory.

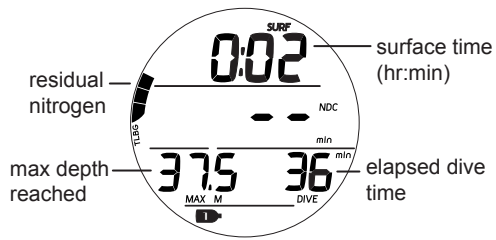

GAS SWITCHES

⚠ WARNINGS:

- Historically, many accidents and near misses have occurred by switching to the wrong gas at the wrong depth. **DO NOT** attempt gas switch decompression dives without proper education and training to do so from an internationally recognized training agency.
- Diving deeper than 39 m (130 ft), will greatly increase your risk of decompression sickness.
- Decompression diving is inherently hazardous and greatly increases your risk of decompression sickness, even when performed according to the dive computer's calculations.
- Using an i200 is no guarantee of avoiding decompression sickness.
- The i200 enters Violation Mode when a situation exceeds its capacity to predict an ascent procedure. These dives represent gross excursions into decompression that are beyond the boundaries and spirit of the i200's design. If you are following these dive profiles, Aqua Lung advises that you should not use an i200.
- If you exceed certain limits, the i200 will not be able to help you get safely back to the surface. These situations exceed tested limits and can result in loss of some functions for 24 hours after the dive in which a violation occurred.

OVERVIEW

- All dives begin with GAS 1.
- The GAS defaults to # 1 after 10 minutes on the surface.
- Gas switches can only be made when a Dive Main screen is displayed.
- Gases cannot be switched while on the surface.
- The Gas Switch Menu cannot be accessed during the sounding of alarms.
- If an alarm strikes while in the Gas Switch Menu, the switch operation is terminated (reverting to the Dive Main screen).

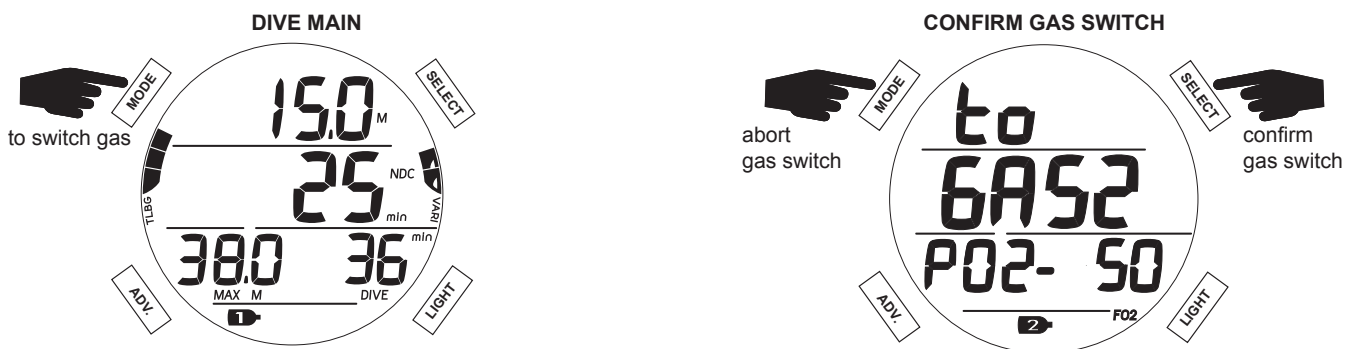

If the current PO_2 value is greater than 1.6, then a warning not to switch will display. The i200 will maintain the current gas without switching. The diver may override the i200 and force the gas switch by pressing the SELECT button during the DO NOT SWITCH TO message.

- ⚠ **WARNING:** Switching to gases with a PO_2 above 1.6 has a high risk of oxygen poisoning, convulsions, and drowning. Doing so should always be avoided. It is intended as a last resort option because of the likelihood of injury or drowning. Always dive within your training, experience, and skill level.



COMPLICATIONS

The preceding information has described standard dive operations. Your new i200 is also designed to help you to the surface in less than ideal situations. The following is a description of these situations. Take some time to familiarize yourself with these operations before diving your i200.

DECOMPRESSION

Decompression (deco) mode activates when theoretical No Decompression time and depth limits are exceeded. Upon entry into decompression, the audible alarm will sound and the alarm LED will flash. The full Tissue Loading Bar Graph and Up Arrow icon will flash until the audible is silenced.

- Once within 3 m (10 ft) below the required Stop Depth (stop zone), the Full Stop icon (both Arrows with Stop Bar) will be displayed solid.

To fulfill your decompression obligation, you should make a safe controlled ascent to a depth slightly deeper than, or equal to, the required stop depth indicated and decompress for the stop time indicated. The amount of decompression credit time that you receive is dependent on Depth, with slightly less credit given the deeper you are below the Stop Depth indicated. You should stay slightly deeper than the required Stop Depth indicated until the next shallower Stop Depth appears. Then you can slowly ascend to that indicated Stop Depth but not shallower.

DECOMPRESSION ENTRY

Upon entry into decompression (deco) the audible alarm will sound and the alarm LED will flash until the audible is silenced. The up arrow and full Tissue Loading Bar Graph icons will flash. Additionally, the stop depth, stop time, and the TAT (Total Ascent Time) values will be displayed. TAT includes stop times at all required Decompression Stops plus vertical ascent time based on the max ascent rate allowed.

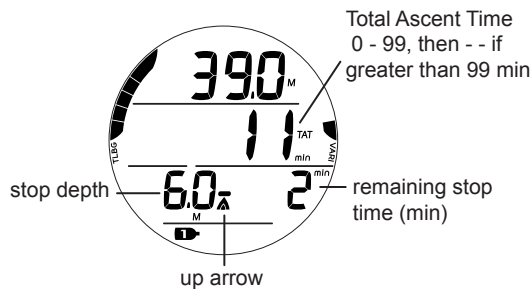

DECOMPRESSION STOP MAIN

Decompression (deco) Stop Main will display upon ascending to within 3 m (10 ft) below the Decompression Stop depth. The full stop graphic (opposed arrows with stop bar) will be displayed solid. While Decompression Stop Main is displayed, you may access up to 3 ALT displays by pressing the ADV button to cycle through them. They are similar to the No Decompression Main, Dive ALT 1, and Dive ALT 2 displays, respectively.

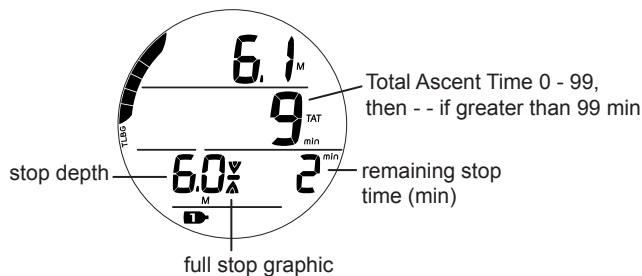

CONDITIONAL VIOLATION (CV)

Upon ascent above the required Decompression (deco) Stop depth, operation will enter Conditional Violation during which time no off gassing credit will be given.

The Audible alarm will sound and the alarm LED will flash. The full Tissue Loading Bar Graph and down arrow will flash until the audible alarm is silenced, then the Tissue Loading Bar Graph will be solid.

- The down arrow continues to flash until descending below the required Stop Depth (within stop zone), then the full stop graphic (opposed arrows with stop bar) will be on solid.
- If you descend deeper than the required Decompression Stop before 5 minutes elapse, Decompression operation will continue with no off gassing credit given for time above the Stop. Instead, for each minute above the Stop 1½ minutes of penalty time will be added to the required Stop Time.
- The added penalty (decompression) time will have to be worked off before obtaining off gassing credit.
- Once the penalty time is worked off, and off gassing credit begins, required Decompression Stop Depths and Time will decrease toward zero. The Tissue Loading Bar Graph will recede into the No Decompression zone, and operation will revert to No Decompression mode.

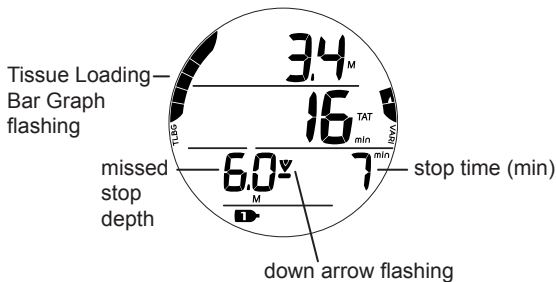

DELAYED VIOLATION 1 (DV 1)

If you remain shallower than a Decompression Stop Depth for more than 5 minutes, operation will enter DV1* which is a continuation of CV with penalty time still being added. Again, the audible alarm will sound and the full Tissue Loading Bar Graph will flash until it is silenced. ALT screens are accessed and appear similar to Decompression ALT screens.

*The difference is that 5 minutes after surfacing from the dive, operation will now enter Violation Gauge Mode.

- The down arrow continues to flash until descending below the required Stop Depth, then the full stop graphic will be on solid.
- If the DV1 status is ignored, the i200 will enter DV1 Surface mode for 5 minutes upon surfacing from the dive. The down arrow, Decompression Stop depth/time, and Surface Time will be displayed. After 5 minutes on the surface in DV1 mode, the unit will enter VGM (Violation Gauge Mode).

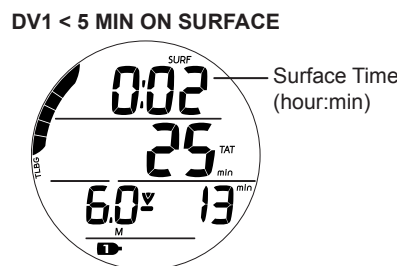
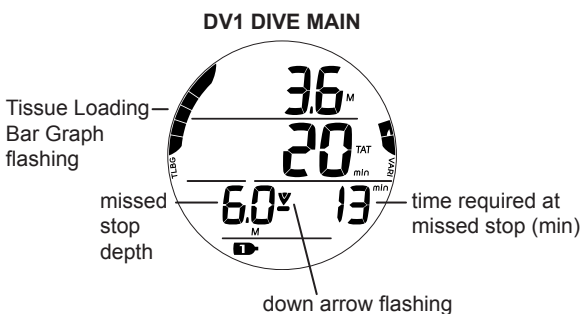

DELAYED VIOLATION 2 (DV 2)

If the calculated Decompression obligation requires a Stop Depth between 18 m (60 ft) and 21 m (70 ft), operation will enter DV2.

The audible alarm will sound and the alarm LED will flash. The full Tissue Loading Bar Graph will flash until the audible is silenced.

- The up arrow flashes if 3 m (10 ft) deeper than the required Stop Depth.
- Once within 3 m (10 ft) of and below the required Stop Depth, the full stop graphic (opposing arrows with stop bar) will be displayed solid.

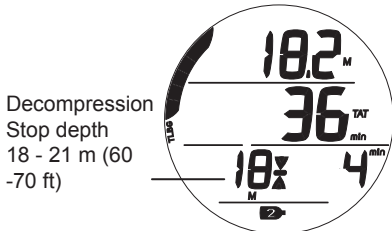

DELAYED VIOLATION 3 (DV 3)

If you descend deeper than the maximum functional depth*, the audible alarm will sound, the alarm LED will flash, and the up arrow will flash. Additionally, Current Depth will only indicate dashes signifying that you are too deep.

*The maximum functional depth (330 ft / 100 m) is the depth at which the i200 can properly perform calculations or provide accurate display information.

Upon ascending above the maximum functional depth, current depth will be restored. However, the log for that dive will display dashes for max depth.

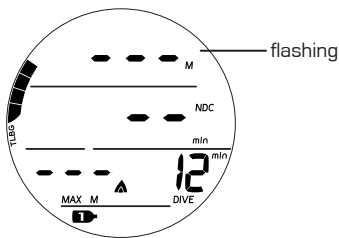

VIOLATION GAUGE MODE (VGM) DURING A DIVE

During Dive mode dives, operation will enter VGM when Decompression requires a Stop Depth greater than 21 m (70 ft). It will also enter VGM if Deco is activated during a dive in Free mode, described later. Operation would then continue in VGM during the remainder of that dive and for 24 hours after surfacing. VGM turns the i200 into a digital instrument without any decompression or oxygen related calculations or displays. Upon activation of VGM, the audible alarm will sound and the alarm LED will flash. The message VIO (violation) with the up arrow will flash. After the audible alarm becomes silent (10 seconds), the NDC (No Decompression) and Tissue Loading Bar Graph will not display for the rest of the dive.

VGM DURING AUDIBLE

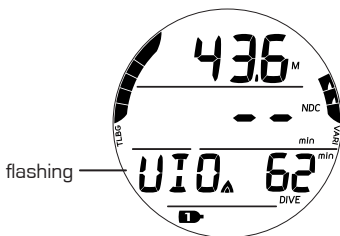

VGM AFTER AUDIBLE

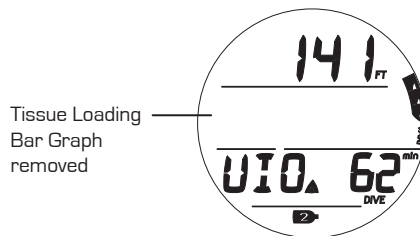

VIOLATION GAUGE MODE (VGM) ON THE SURFACE

The message VIO (violation) is displayed until 24 hours elapse with no dives. During that 24 hours, VGM lockout does not allow access to the Set Gas, Plan, Desat, and Free mode features/screens. All Watch functions will be allowed.

- The Fly countdown timer provides the time remaining before normal operation can resume with full features and functions.
- In the event that a dive is made during the 24 hour lockout period, a full 24 hour surface interval must then be served before all functions are restored.

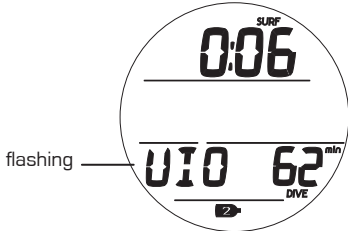

HIGH PO₂

Warning >> at Alarm Set Point value minus .20

Alarm >> at Set Point value, except in Deco then at 1.60 only

Warning

When PO₂ (partial pressure of oxygen) increases to the Warning level; the audible alarm sounds and the PO₂ value will flash (in place of max depth) until the audible alarm is silenced.

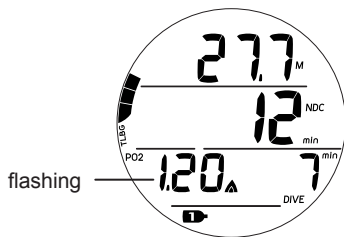

Alarm

If PO₂ continues to increase and reaches the alarm set point, the audible alarm sounds again. The PO₂ value will flash in place of max depth during the audible alarm. After the audible alarm is silenced, the PO₂ will alternate with max depth. Additionally, the up arrow will flash continually until PO₂ decreases below the alarm set point.

DURING AUDIBLE ALARM

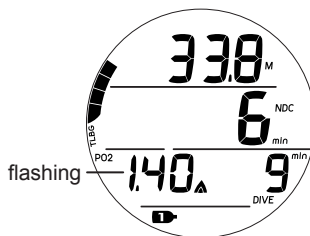

AFTER AUDIBLE ALARM

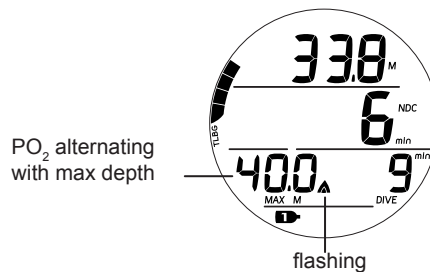

PO₂ During Decompression

The PO₂ alarm setting does not apply when in Decompression. If PO₂ reaches 1.60 while at a Decompression Stop, the PO₂ value (1.60) with icon will alternate with decompression stop depth/time until the PO₂ value decreases below 1.60.

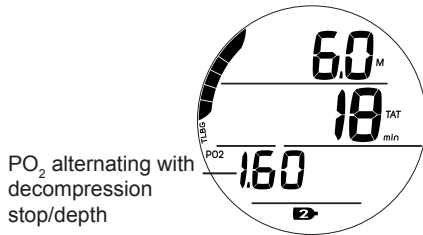

HIGH O₂ SAT (OXYGEN SATURATION)

Warning >> at 80 to 99% (240 OTU)

Alarm >> at 100% (300 OTU)

Warning

When O₂ reaches the Warning Level, the audible alarm sounds and the O₂ SAT (saturation) value will flash in place of the DTR (Dive Time Remaining). The DTR will be restored when the audible alarm is silenced.

DURING AUDIBLE ALARM

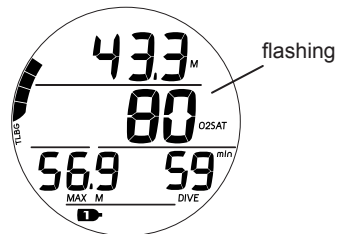

AFTER AUDIBLE ALARM

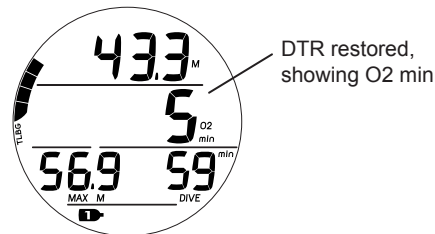

Alarm

If O₂ SAT reaches the Alarm level, the audible alarm sounds. At the same time, the up arrow and the O₂ SAT value will flash in place of DTR until surfacing.

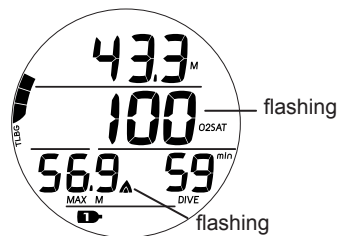

Warning During Decompression

When O₂ SAT reaches the Warning Level, the audible alarm sounds and the O₂ SAT value will flash in place of Total Ascent Time. The Total Ascent Time will be restored when the audible alarm is silenced.

DURING AUDIBLE ALARM

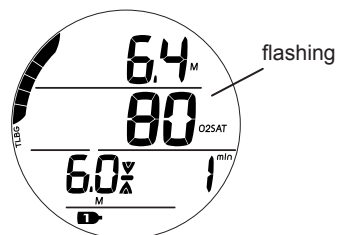

Alarm During Decompression

When O2 SAT reaches the Alarm Level, the audible alarm sounds and the O2 SAT value will flash in place of Total Ascent Time until surfacing.

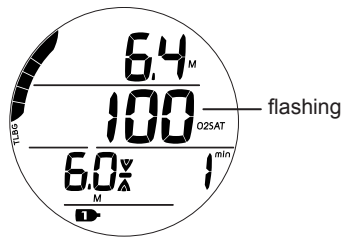

Alarm On Surface

- If O2 SAT is 100% upon surfacing while in No Decompression, O2 SAT 100% will flash until the O2 SAT value decreases below 100%.
- If you surface due to 100% O2 without having completed the Decompression obligation, the full TLBG and O2 value (100) will flash with O2SAT icons for the first 10 minutes, then operation will enter Violation Gauge Mode.

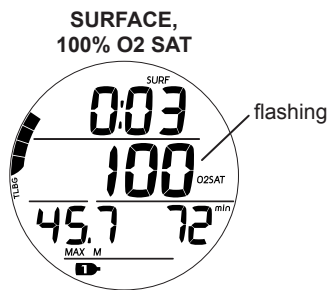

GAUGE MODE

ON THE SURFACE BEFORE A DIVE

There are two Gauge Surface Main screens. The first screen displays when there have been no dives yet or the surface interval after a dive has exceeded 10 min. The second screen displays only during the first ten minutes after a dive.

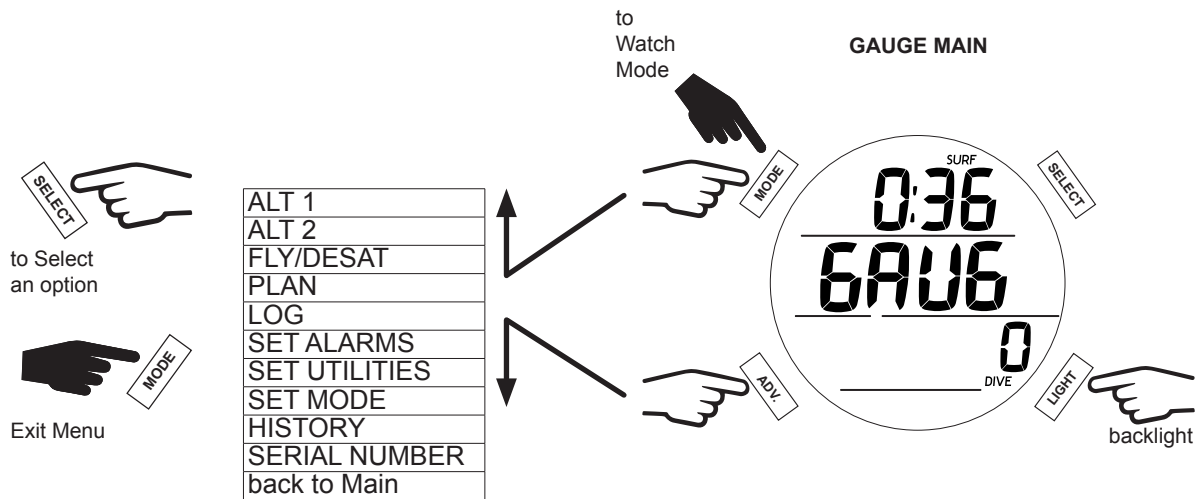
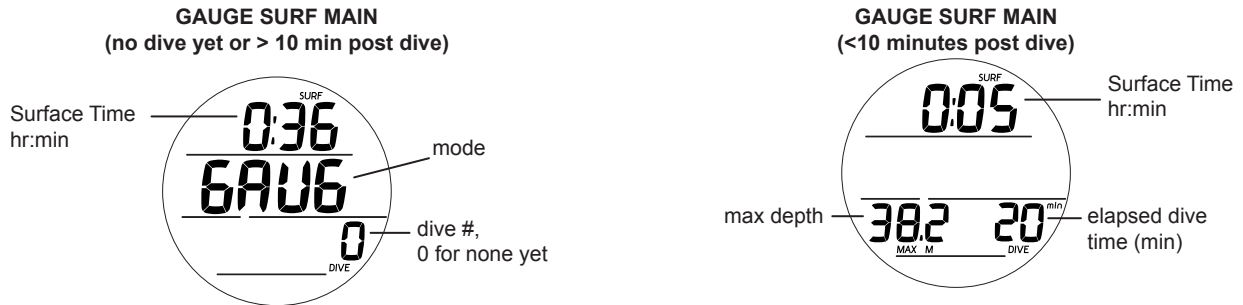

NOTE: Gauge Surface ALT screens and Menu options are similar to those described previously for Dive Mode. See the Dive Surface Mode chapter for further details. Features unique to Gauge Mode are described in the following sections.

INITIATING A DIVE

With the i200 in Gauge Mode, a dive will commence upon descending to 1.5 m (5 ft) for longer than 5 seconds. Below is a diagram to help you navigate Gauge Dive Mode functions. The dive will end and revert to Surface Mode upon ascent to 0.9 m (3 ft) of depth for at least 1 second.

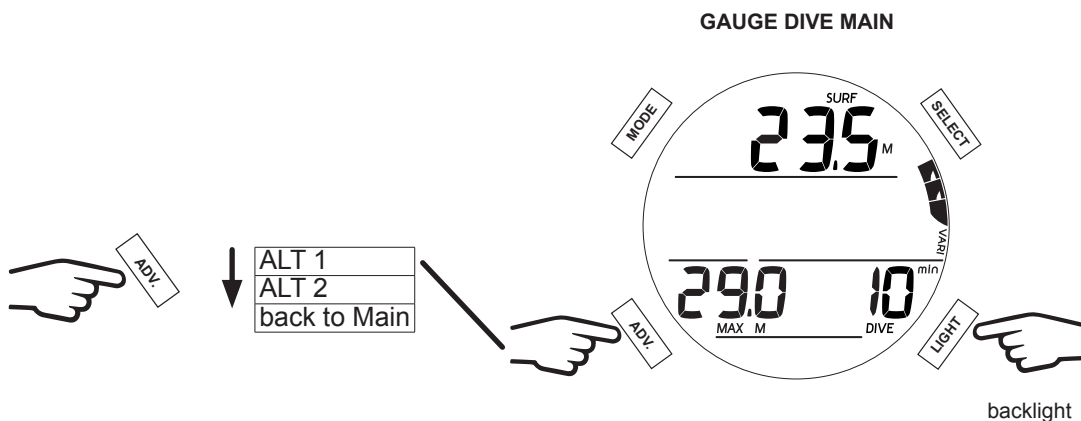

GAUGE DIVE MAIN

The Gauge Dive Main provides basic information including depth, dive time, max depth, and ascent rate during the dive.

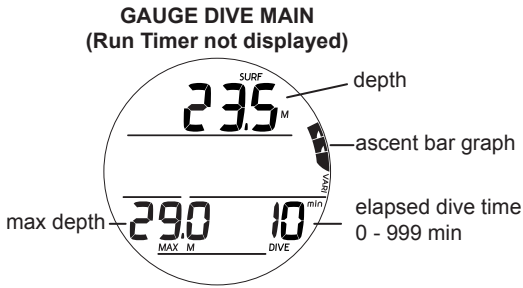

GAUGE DIVE ALT 1

This screen only displays when the Run Timer is displayed on the Dive Main screen. Otherwise, it is bypassed. It is equal to the Gauge Dive Main screen.

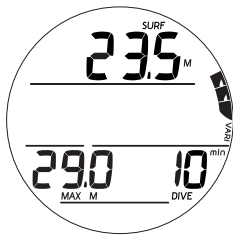

GAUGE DIVE ALT 2

This screen simply tells you the current time of day and ambient temperature.



RUN TIMER

The Gauge Mode allows for a Run Timer to be added to the Gauge Dive Main screen.

NOTE: Once the Run Timer is added and started, it can be removed and continue to run in the background until it is again added. Though it can only be started and stopped while it is being displayed.

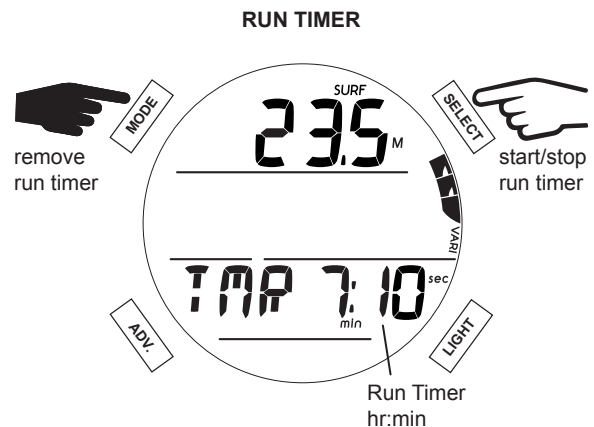
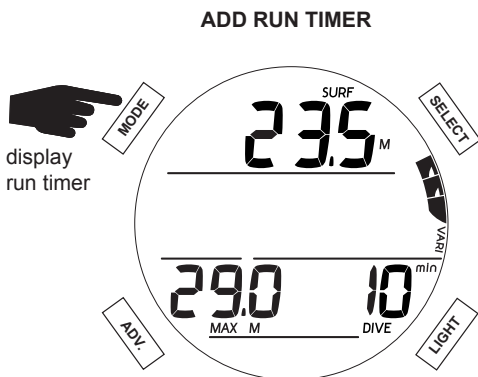

DELAYED VIOLATION 3 (DV3)

If you descend deeper than the maximum functional depth*, the audible alarm will sound and the alarm LED will flash. At the same time, the up arrow will flash and depth will only indicate dashes signifying that you are too deep. The max depth will also be represented by dashes.

*The maximum functional depth (100 m / 330 ft) is the depth at which the i200 can properly perform calculations or provide accurate display information.

Upon ascending above the maximum functional depth, current depth will be restored, however, max depth will continue to be displayed as dashes for the remainder of that dive. The Log for that dive will also display dashes for max depth.

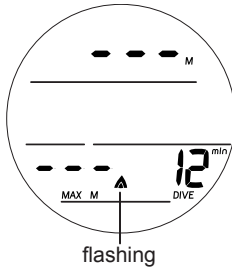

FREE MODE

FREE DIVE MODE DETAILS

- Although breathing apparatus is not utilized for free dive activities, nitrogen tissue loading remains a factor. Nitrogen loading is calculated based upon a fixed FO_2 of Air.
- Since a user has the option of alternating between SCUBA and free dive activities within a 24 hour period, nitrogen calculations and the displayed value of No Decompression Dive Time Remaining are carried over from one operating mode to the other, which permits the user to maintain awareness of nitrogen absorption and off-gassing status.
- The mathematical models currently used in the i200 are based on no decompression/decompression multilevel repetitive dive schedules.
- These algorithms do not take into account the physiological changes associated with the high pressures that competitive type free diving can expose a diver to.

WARNINGS:

- **Ensure that you know which operating mode is selected (Dive, Gauge, or Free) prior to commencing any dive.**
- **Conducting Free dives within a 24 hour period after conducting SCUBA dives, combined with the effects of multiple rapid free dive ascents, increases your risk of decompression sickness. Such activities may result in accelerated entry into decompression which could cause serious injury or death.**
- **Combining competitive type free dive activities that involve multiple descents/ascents with activities utilizing SCUBA during the same 24 hour period is not recommended. Presently, there is no data relating to such activities.**
- **It is highly recommended that anyone planning to become involved in competitive type free dive activities obtain proper instruction and training from a recognized free diving trainer. It is imperative that the physiological affects be understood and the diver is physically prepared.**

ON THE SURFACE BEFORE A DIVE

There are two Free Surface Main screens. The first screen displays when no dives have been made or greater than one minute after surfacing. The second screen displays only during the first minute after a dive.

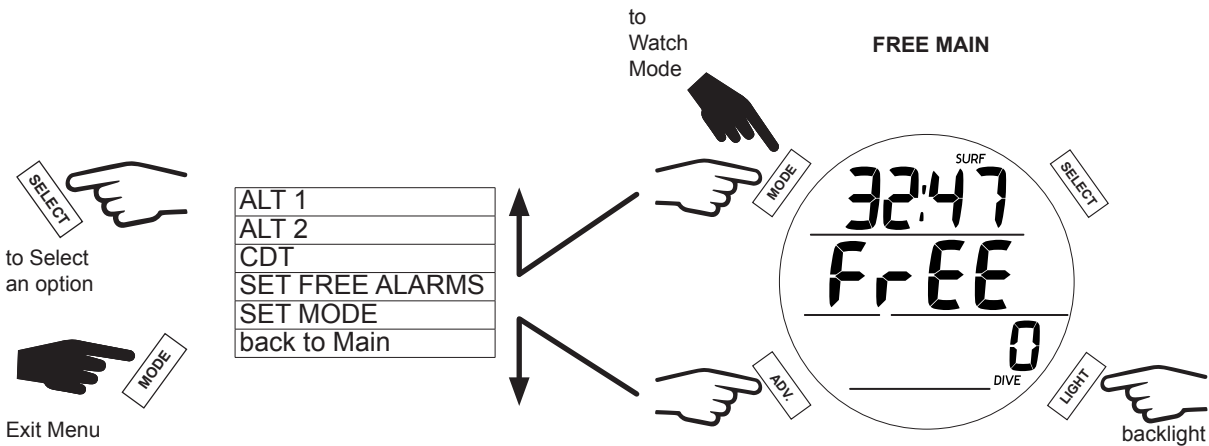
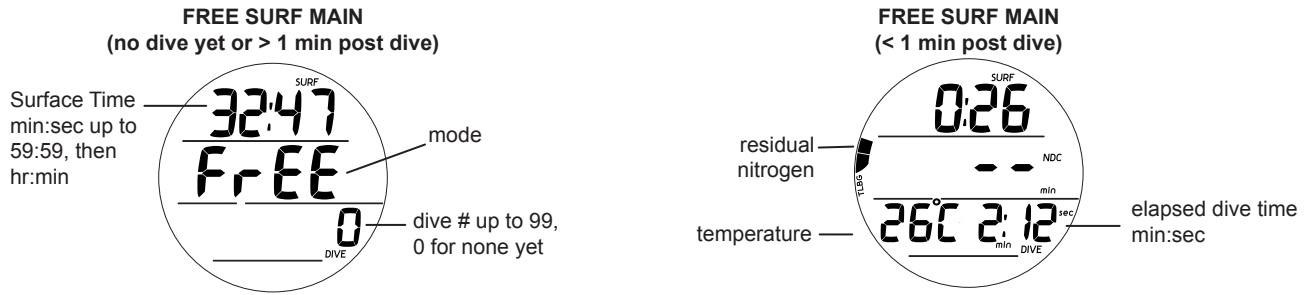

ALT 1

This screen displays data from the previous dive.

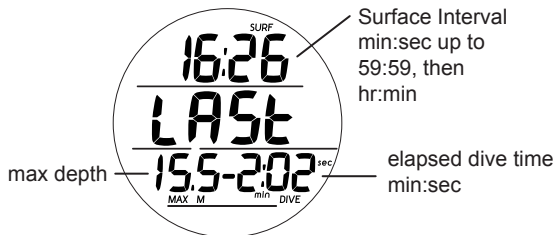

ALT 2

This screen displays current time of day, temperature, and elevation.



COUNTDOWN TIMER (CDT)

The i200 allows you to set a CDT time from 0:01 - 59:59 (min:sec). On the surface the CDT must be started and stopped in the CDT Status screen by selecting ON or OFF. The CDT will run in the background, while on the surface and during dives, until it counts down to 0:00, or it is turned OFF. When a set CDT time reaches 0:00, the audible will sound. During which time the graphic CDT will be displayed flashing on the Surface or Dive Main until the audible is silent.

NOTE: Setting the CDT does not start the countdown. You must select ON in the CDT Status screen to start the CDT.

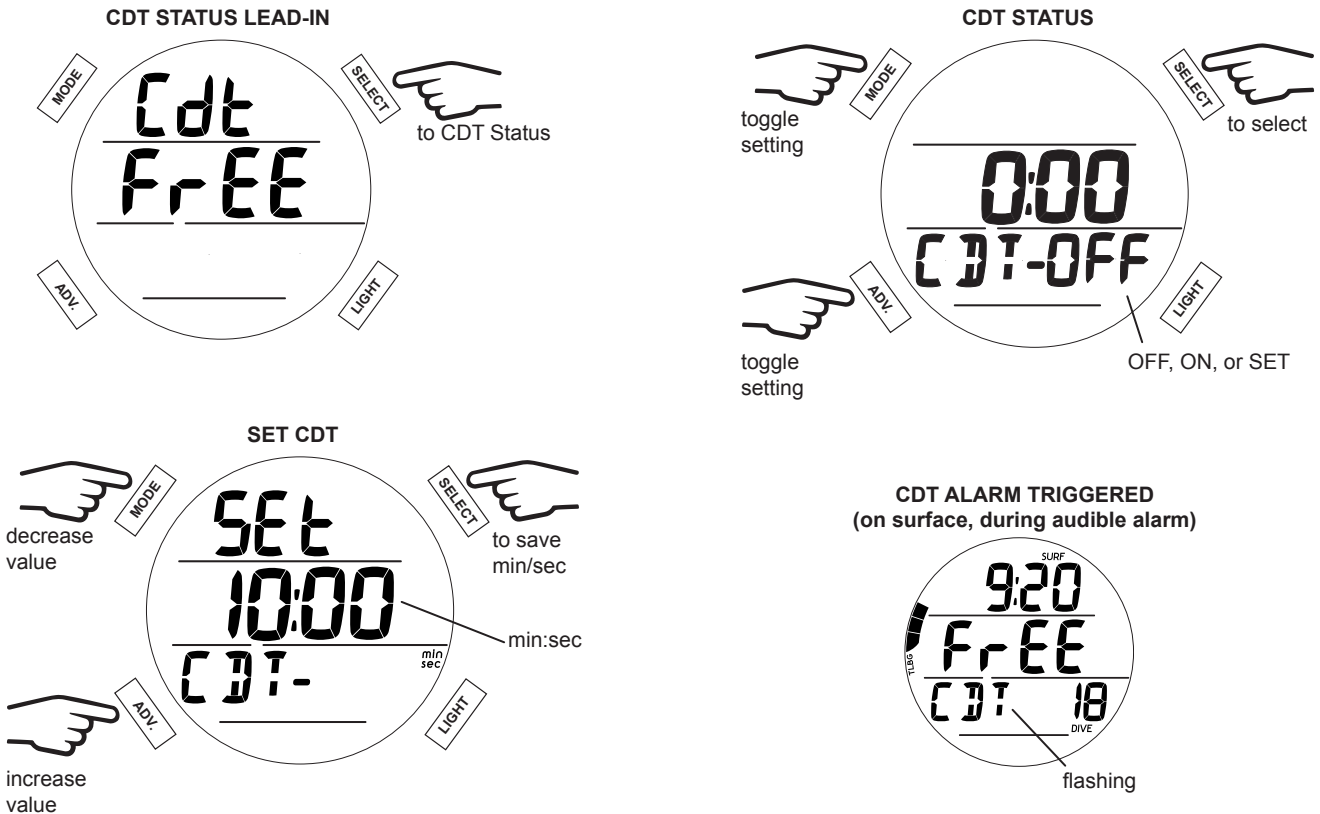

SET ALARMS

Within this submenu you can customize the following Free Mode alarm settings.

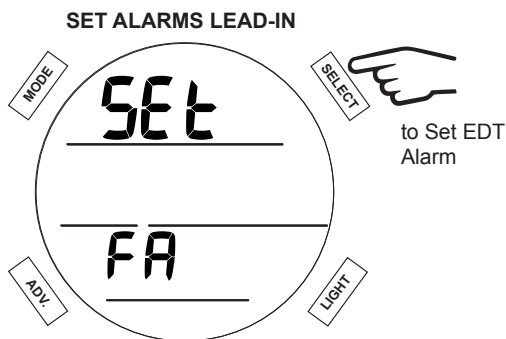

1. Elapsed Dive Time Alarm

The EDT (Elapsed Dive Time) Alarm sounds the audible alarm every 30 seconds while underwater in Free Dive mode.

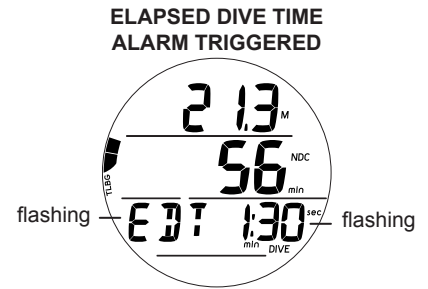
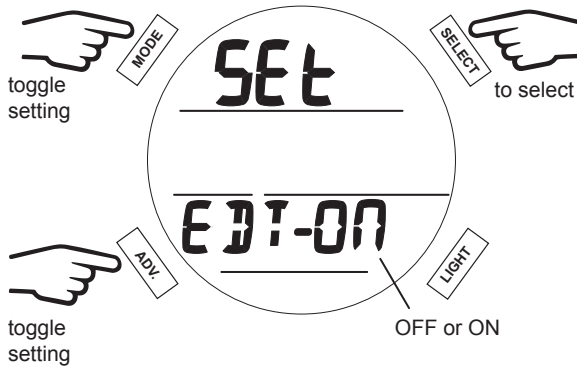

2. Depth Alarms 1-3

There are 3 Free Depth Alarms that can be set at progressively deeper depths, in intervals of 1 m (10 ft).

NOTE: Each successive Depth Alarm can only be set deeper than the Depth Alarm that precedes it. For example: If Depth Alarm 1 is set for 10 m then Depth Alarm 2 settings start at 11 m.

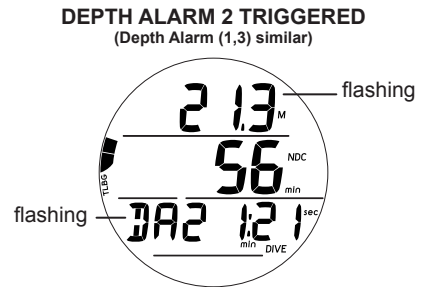
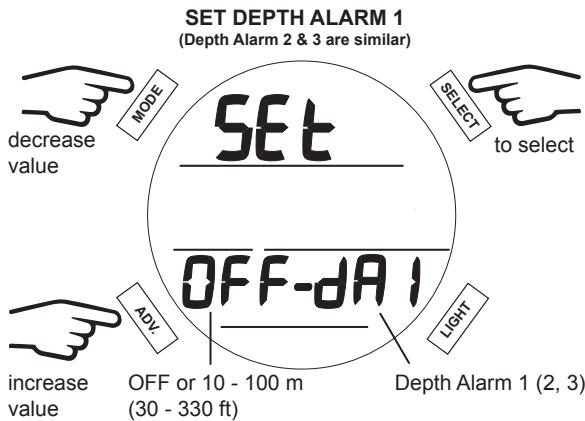

SET MODE (OPERATION MODE)

This feature functions the same as in Dive Mode, see pg. 36.

INITIATING A DIVE

With the i200 in Free Mode, a dive will commence upon descending to 1.5 m (5 ft) for longer than 5 seconds. Below is a diagram to help you navigate Free Dive Mode functions. The dive will end and revert to Surface Mode upon ascent to 0.9 (3 ft) of depth for at least 1 second.

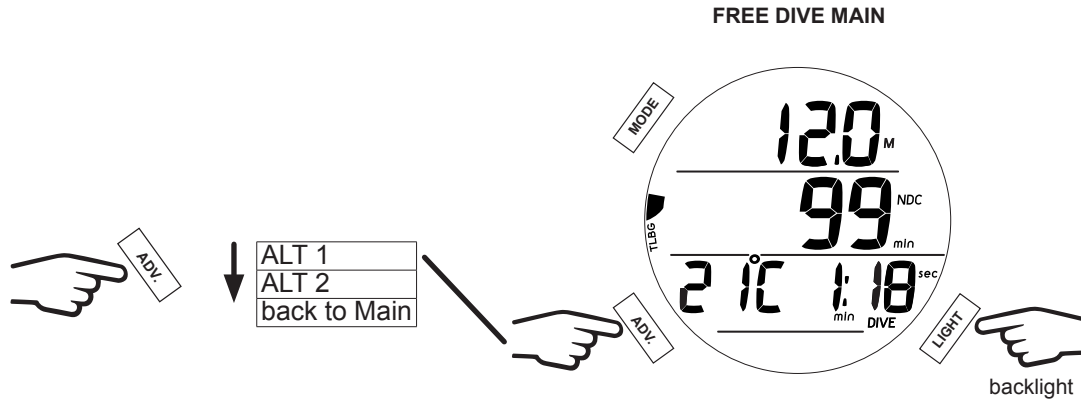

FREE DIVE MAIN

The Free Dive Main provides basic information including depth, no decompression time, dive time, temperature and nitrogen loading during the dive.

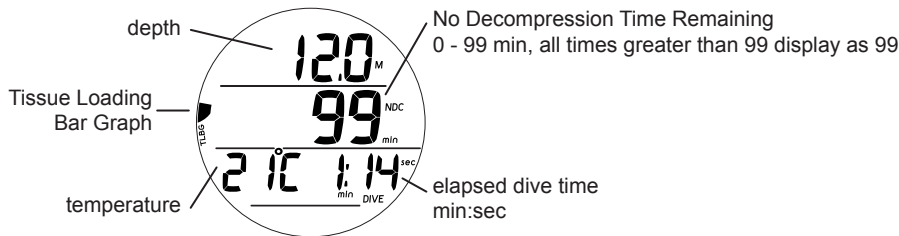

FREE DIVE ALT 1

This screen Displays the Countdown Timer status. The Countdown Timer can be started and stopped in this screen by selecting ON or OFF. After the time runs down to 0:00, the countdown timer will reset to the original preset time.

NOTE: The Countdown Timer must be preset on the surface while in the Free Surface Mode.



FREE DIVE ALT 2

This screen simply tells you the max depth and current time of day.



HIGH NITROGEN ALARMS

When nitrogen increases to the caution level (4 Tissue Loading Bar Graph segments), the audible alarm will sound 3 sets of 3 beeps. During this time the Tissue Loading Bar Graph segments will flash on the Free Dive Main screen.

If nitrogen continues to increase to the Decompression level (all 5 Tissue Loading Bar Graph segments), the audible alarm will sound again. At this time the Tissue Loading Bar Graph segments will flash, and NDC (no decompression) time will be displayed as 0 min.

When the audible alarm is silenced, the Tissue Loading Bar Graph and NDC (no decompression), values are removed. Then the message VIO (violation) and the Up Arrow flashes until on the surface.

After surfacing, the graphic VIO (violation) flashes. Then after 1 minute on the surface, the dive computer operation locks into Violation Gauge Mode for 24 hours. Access to Watch Mode will be as usual.

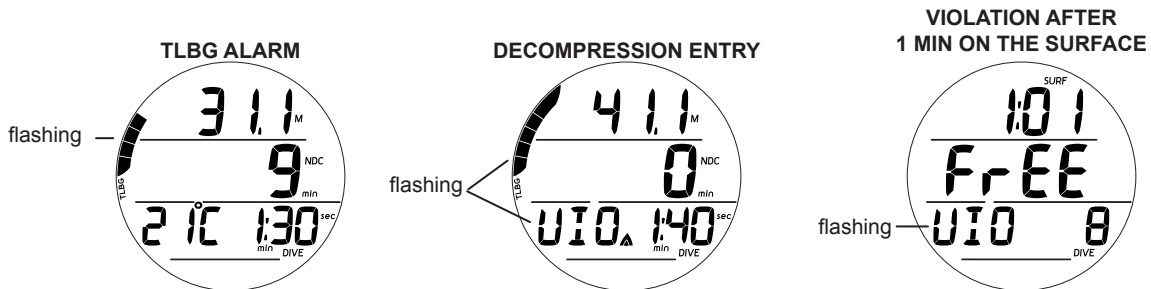

REFERENCE

PC INTERFACE

The Settings Upload portion of the PC Interface (PCI) program can be used to set/change Time, Alarms, and Utilities using the Interface System. The gas mixes and operation modes must be entered using the i200's button controls.

Information available for retrieval (download) from the i200 to the PC program includes items such as dive number, surface interval, max depth, elapsed dive time, start date/time, lowest temperature, sampling rate, and dive profile.

Prior to attempting to download data from your i200 or upload settings to it, review the Help section of the download program.

The USB Driver required for the interface system is downloadable from www.aqualung.com. It must be installed on your PC prior to use of the Interface System.

The i200 is configured with a Data Port located on the rear of the housing that enables it to be connected to a PC USB port using the special Interface Cable.

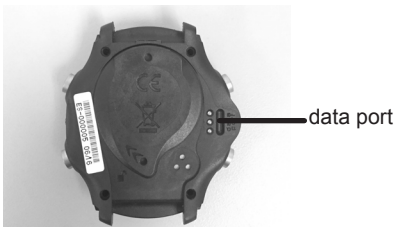

To connect the PC Interface Cable to the i200:

- Attach the Interface Cable as shown.
- Ensure the connection is secure.



The i200 checks for an external access request every second while Watch Main Time is displayed.

Checks are not made if the activation contacts are wet.

For a connection to be made, the download program must be installed on the PC or Mac and open, the associated USB driver must be installed, and the interface cable must be plugged into the PC or Mac USB Port, then connected to the i200's data port.

Upon sensing an interface connection, the requesting device (PC) connects to the i200 and is prepared for upload of settings or download of data. This is then initiated using the PC program. During the process, there is a 2 minute window during which a PC countdown screen is displayed on the i200. Upload or download must be started during this time. When the connection is made all segments of the screen will illuminate.

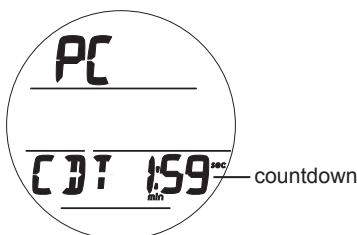

When the operation is initiated using the PC or Mac program, all segments illuminate and remain displayed until completion of the upload/download operation. Then the Watch Main screen is displayed and the cable disconnected.

CONNECTED TO PC

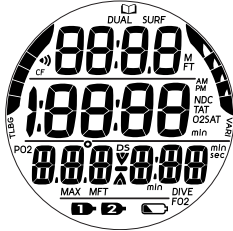

The download software will also accommodate uploads of select firmware (operating software) releases to the i200 using the same PC or Mac interface program and cable.

CARE AND CLEANING

Protect your i200 from shock, excessive temperatures, exposure to chemicals, and tampering. Protect the lens against scratches with an Instrument Lens Protector. Small scratches will naturally disappear underwater.

- Soak and rinse the i200 in fresh water at the end of each day of diving, and check to ensure that the areas around the Low Pressure (Depth) Sensor, PC Interface Data Port, and buttons are free of debris or obstructions.
- To dissolve salt crystals, use lukewarm water or a slightly acidic bath (50% white vinegar/50% fresh water). After removal from the bath, place the i200 under gently running fresh water. Towel dry before storing.
- Keep your i200 cool, dry, and protected during transport.

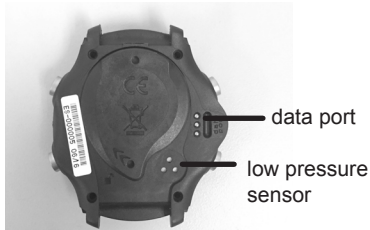

SERVICE

⚠ WARNING: At a minimum, annually check the altitude reading on the ALT 2 screen (p. 13, 26) and Pre-Dive Planner (p. 27, 66) for accuracy. If your i200 is ever out of calibration (incorrect elevation reading, incorrect No Deco Dive Times in the planner, or showing a depth reading at the surface) or displays an error code message (EEP, ALT, CAL, ERR, CSM, A-D), it must be serviced at the factory before use.

If required to return your i200 to Aqua Lung:

- Obtain an RA (Return Authorization) number by contacting your local authorized Aqua Lung Retailer.
- Record all dive data in the Log and/or download the data stored in memory. All data will be erased during factory service.

BATTERY REPLACEMENT

- **NOTE:** The procedures that follow must be closely adhered to avoid entrance of water into the unit. Damage due to improper battery replacement (or subsequent leakage of moisture into the unit) is not covered by the i200's warranty.
- **NOTE:** The i200 can be sent to Aqua Lung, Regional Distributor, or Authorized Dealer Service Facility for proper battery change service which includes pressure (depth) and leak testing to the max operating depth. Standard charges for service will apply.

The battery compartment should be opened only in a dry and clean environment with extreme care taken to prevent the entrance of moisture or dust.

As an additional precautionary measure to prevent formation of moisture in the battery compartment, it is recommended that the battery be changed in an environment equivalent to the local outdoor temperature and humidity (e.g., do not change the battery in an air conditioned environment then take it outside during a hot sunny day).

Inspect the buttons, lens, and housing to ensure they are not cracked or damaged. If there is any sign of moisture in the i200, **DO NOT** attempt to use it for diving until it receives proper service by the Aqua Lung factory or an authorized regional distributor.

Data Retention

When the battery is removed, settings and nitrogen/oxygen calculations for repetitive dives will be retained in volatile memory until a new battery is installed.

All parts needed for the battery change are provided in the i200 Battery Kit available from your Aqua Lung Dealer.

Battery Removal

- It is not necessary to remove the wrist straps.
- Locate the battery compartment on the back of the unit.
- Rotate the battery cover clockwise 10 degrees using the special Battery Cover Tool, or by pushing the lower portion to the left while pushing the upper portion to the right using your thumbs.
- Lift the cover and O-ring up and away from the housing.
- Using care not to damage the contact, slide the battery up and out of the left side of the compartment.
- Turn the case to one side to drop the battery into your hand. If necessary, gently loosen it with the tip of your finger. **DO NOT** use tools to pry it out, or short the positive (+) top of the Battery to the negative (-) contact under it.
- Discard the battery according to local regulations governing disposal of lithium batteries.

COVER REMOVAL



BATTERY REMOVAL



Inspection

- Closely check all of the sealing surfaces for any signs of damage that might impair proper sealing.
- Inspect the button, lens, and housing to ensure they are not cracked or damaged.

⚠ WARNING: If damage or corrosion is found, return your i200 to an authorized Aqua Lung dealer, and DO NOT attempt to use it until it has received factory prescribed service.

- Remove the cover O-ring. Discard, and **DO NOT** attempt to reuse it.

⚠ CAUTION: DO NOT use tools to remove the O-ring. To ensure proper sealing, O-ring replacement is required each time the battery is replaced.

REMOVE O-RING

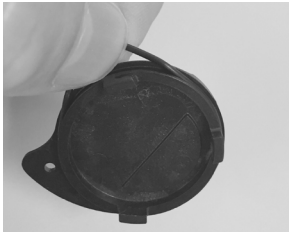

Battery Installation

⚠ CAUTION: The O-ring must be a genuine Aqua Lung part that can be purchased from an authorized Aqua Lung dealer. Use of any other O-ring will void the warranty.

- Very lightly lubricate the new O-ring with silicone grease and place it in the O-ring groove of the cover.
- Place a new 3 volt type CR2430 lithium battery, negative side down into the battery cavity. Ensure that it is evenly positioned.
- Carefully place the battery cover (with O-ring) into position on the rim of the battery compartment, then press it evenly and completely down into place.
- Maintain the battery cover securely in place and turn it counter clockwise 10 degrees using the special battery cover tool, or by pushing the lower portion to the right while pushing the upper portion to the left.

REPLACE O-RING

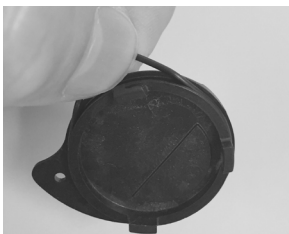

INSTALL BATTERY



INSTALL COVER



Testing

- Activate the unit and ensure that the LCD is clear and sharp in contrast. If any portions are missing or appear dim, or if a low battery condition is indicated, return the i200 to an authorized Aqua Lung dealer for evaluation before use.
- Verify all set points prior to diving.

ALTITUDE SENSING AND ADJUSTMENT

Prior to the first dive of a series of repetitive dives, Altitude (i.e., ambient pressure) is measured upon activation of Dive Surface Mode and every 15 minutes until a dive is made or operation reverts to Watch Mode.

- While it is operating in Watch Mode after a dive, measurements are taken every 15 minutes during the 24 hour period after surfacing.
- Measurements are only taken when the unit is dry.
- Two readings are taken, the second reading 5 seconds after the first. The readings must be within 1 foot (30 cm) of each other to record that ambient pressure as the current altitude.
- No adjustments are made during any time that the wet contacts are bridged.

When diving in high altitude waters from 916 to 4,270 m (3,001 to 14,000 ft), the i200 automatically adjusts to these conditions providing corrected depth, and reduced No Deco and O₂ Times at intervals of 305 m (1,000 ft).

At an elevation of 916 m (3,001 ft), Depth calibration automatically changes from feet of seawater to feet of fresh water. This is the first adjustment to the algorithm. When the Conservative Factor feature is set to ON, No Deco Times are calculated based upon the next higher 915 m (3,000 ft) Altitude. All adjustments for altitudes greater than 3,355 m (11,000 ft) are then made to allowable dive times for 4,270 m (14,000 ft). At Sea Level, calculations are based upon an altitude of 6,000 ft.

The i200 will not function as a dive computer above 4,270 m (14,000 ft).

TECHNICAL DATA

NO DECOMPRESSION TIME LIMITS

PZ+ ALGORITHM >> NDLS (HR:MIN) AT ALTITUDE (METRIC)

Altitude (meters)	0 to 915	916 to 1220	1221 to 1525	1526 to 1830	1831 to 2135	2136 to 2440	2441 to 2745	2746 to 3050	3051 to 3355	3356 to 3660	3661 to 3965	3966 to 4270
Depth (M)												
9	3:37	2:41	2:31	2:23	2:16	2:10	2:04	1:59	1:54	1:50	1:43	1:37
12	1:55	1:27	1:21	1:15	1:12	1:08	1:05	1:03	1:00	0:58	0:55	0:54
15	1:08	0:55	0:53	0:51	0:49	0:47	0:44	0:42	0:39	0:37	0:36	0:34
18	0:50	0:39	0:37	0:35	0:33	0:32	0:30	0:28	0:26	0:24	0:23	0:22
21	0:36	0:28	0:26	0:24	0:23	0:21	0:20	0:19	0:18	0:17	0:16	0:16
24	0:27	0:20	0:19	0:18	0:17	0:16	0:15	0:14	0:13	0:12	0:11	0:11
27	0:20	0:16	0:15	0:13	0:12	0:11	0:11	0:10	0:09	0:09	0:09	0:08
30	0:16	0:12	0:11	0:10	0:09	0:09	0:09	0:08	0:08	0:07	0:07	0:07
33	0:13	0:09	0:09	0:08	0:08	0:07	0:07	0:07	0:07	0:06	0:06	0:06
36	0:10	0:08	0:07	0:07	0:07	0:06	0:06	0:06	0:05	0:05	0:05	0:05
39	0:09	0:07	0:06	0:06	0:06	0:06	0:05	0:05	0:05	0:05	0:05	0:04
42	0:08	0:06	0:06	0:05	0:05	0:05	0:05	0:05	0:04	0:04	0:04	0:04
45	0:06	0:05	0:05	0:05	0:05	0:04	0:04	0:04	0:04	0:04	0:04	0:04
48	0:06	0:05	0:05	0:04	0:04	0:04	0:04	0:04	0:04	0:03	0:03	0:03
51	0:05	0:04	0:04	0:04	0:04	0:04	0:04	0:03	0:03	0:03	0:03	0:03
54	0:05	0:04	0:04	0:04	0:04	0:03	0:03	0:03	0:03	0:03	0:03	0:03
57	0:05	0:04	0:04	0:03	0:03	0:03	0:03	0:03	0:03	0:03	0:03	0:03

PZ+ ALGORITHM >> NDLS (HR:MIN) AT ALTITUDE (IMPERIAL)

Altitude (feet)	0 to 3000	3001 to 4000	4001 to 5000	5001 to 6000	6001 to 7000	7001 to 8000	8001 to 9000	9001 to 10000	10001 to 11000	11001 to 12000	12001 to 13000	13001 to 14000
Depth (FT)												
30	3:17	2:30	2:21	2:14	2:08	2:02	1:57	1:52	1:47	1:39	1:34	1:29
40	1:49	1:21	1:15	1:11	1:08	1:05	1:02	1:00	0:57	0:55	0:53	0:51
50	1:05	0:53	0:51	0:49	0:47	0:44	0:42	0:39	0:37	0:35	0:34	0:33
60	0:48	0:37	0:35	0:33	0:32	0:30	0:28	0:26	0:24	0:23	0:22	0:21
70	0:35	0:26	0:24	0:23	0:21	0:20	0:19	0:18	0:17	0:16	0:16	0:14
80	0:26	0:19	0:18	0:17	0:16	0:15	0:14	0:13	0:12	0:11	0:11	0:10
90	0:19	0:15	0:14	0:13	0:12	0:11	0:10	0:10	0:09	0:09	0:08	0:08
100	0:16	0:11	0:10	0:10	0:09	0:09	0:08	0:08	0:07	0:07	0:07	0:07
110	0:12	0:09	0:08	0:08	0:08	0:07	0:07	0:07	0:06	0:06	0:06	0:05
120	0:10	0:08	0:07	0:07	0:07	0:06	0:06	0:06	0:05	0:05	0:05	0:05
130	0:08	0:07	0:06	0:06	0:06	0:05	0:05	0:05	0:05	0:05	0:04	0:04
140	0:07	0:06	0:05	0:05	0:05	0:05	0:05	0:04	0:04	0:04	0:04	0:04
150	0:06	0:05	0:05	0:05	0:05	0:04	0:04	0:04	0:04	0:04	0:04	0:03
160	0:06	0:05	0:05	0:04	0:04	0:04	0:04	0:04	0:04	0:03	0:03	0:03
170	0:05	0:04	0:04	0:04	0:04	0:04	0:03	0:03	0:03	0:03	0:03	0:03
180	0:05	0:04	0:04	0:04	0:03	0:03	0:03	0:03	0:03	0:03	0:03	0:03
190	0:04	0:04	0:04	0:03	0:03	0:03	0:03	0:03	0:03	0:03	0:03	0:00

ALTITUDE LEVELS

DISPLAY	RANGE: METERS (FEET)
SEA	0 to 915 (0 to 3,000)
EL2	916 to 1,525 (3,001 to 5,000)
EL3	1,526 to 2,135 (5,001 to 7,000)
EL4	2,136 to 2,745 (7,001 to 9,000)
EL5	2,746 to 3,355 (9,001 to 11,000)
EL6	3,356 to 3,965 (11,001 to 13,000)
EL7	> 3,965 (13,000)

OXYGEN EXPOSURE LIMITS

(from NOAA Diving Manual)

PO ₂ (ATA)	MAX DURATION SINGLE EXPOSURE (MIN)	MAX TOTAL DURATION 24 HOUR DAY (MIN)
0.60	720	720
0.70	570	570
0.80	450	450
0.90	360	360
1.00	300	300
1.10	240	270
1.20	210	240
1.30	180	210
1.40	150	180
1.50	120	180
1.60	45	150

SPECIFICATIONS

CAN BE USED AS

- Watch
- Dive Computer (Air or Nitrox)
- Digital Depth Gauge/Timer
- Free Dive Computer

DIVE COMPUTER PERFORMANCE

- Bühlmann ZHL-16C based PZ+ algorithm
- Decompression in agreement with Bühlmann ZHL-16C
- No Decompression Deep Stops - Morroni, Bennett
- Decompression Deep Stops (not recommended) - Blatteau, Gerth, Gutvik
- Altitude - Bühlmann, IANTD, RDP (Cross)
- Altitude corrections and O2 limits based on NOAA tables

OPERATIONAL PERFORMANCE

- | | |
|-----------|-------------------|
| Function: | Accuracy: |
| • Depth | ±1% of full scale |
| • Timers | 1 second per day |

Dive Counter:

- DIVE/GAUGE displays Dives #1 to 24, FREE displays #1 to 99 (0 if no dive made)
- Resets to Dive #1, upon diving (after 24 hours with no dives)

Dive Log Mode:

- Stores 24 most recent DIVE/GAUGE dives in memory for viewing
- After 24 dives, adds 25th dive in memory and deletes the oldest dive

Altitude:

- Operational from sea level to 4,270 m (14,000 ft) elevation
- Measures ambient pressure every 30 minutes when inactive, upon activation, every 15 minutes while activated.
- Does not measure ambient pressure when wet.
- Compensates for Altitudes above sea level beginning at 916 m (3,001 ft) elevation and every 305 m (1,000 ft) higher.

Power:

- (1) 3 volt, CR2430, lithium battery (Panasonic or equivalent)
- Shelf life Up to 7 years (dependent on battery manufacturer)
- User replacement battery (annual recommended)
- Use Life 1 year or 300 dive hours if (qty: 2) 1 hour dives per dive day.

Battery Icon:

- Warning - icon on solid at 2.75 volts, Battery change recommended
- Alarm - icon on flashing at 2.50 volts, change the Battery

Operating Temperature:

- Out of the water - between -6.6 and 60 °C (20 °F and 140 °F).
- In the water - between -2.2 and 35 °C (28 °F and 95 °F).

Tissue Loading Bar Graph

- No Decompression Normal Zone 1 to 3
- No Decompression Caution Zone 4
- Decompression Zone 5 (all)

segments

Ascent (VARI) Rate

	<u>Segments</u>	<u>MPM</u>	<u>FPM</u>
• Normal zone	0	0 - 3	0 - 10
• Normal zone	1	3.5 - 4.5	11 - 15
• Normal zone	2	5 - 6	16 - 20
• Normal zone	3	6.5 - 7.5	21 - 25
• Caution zone	4	8 - 9	26 - 30
• Too Fast zone (flashing)	5 (all)	> 9	> 30

NUMERIC DISPLAYS:

	<u>Range:</u>	<u>Resolution:</u>
• Dive Number	0 to 24	1
• Depth	0 to 100 m (330 ft) (0 - 99.9 M, > 99.9 then 100 M)	.1/1 M (1 FT)
• FO ₂ Set Point	Air, 21 to 100 %	1 %
• PO ₂ Value	0.00 to 5.00 ATA	0.01 ATA
• Dive Time Remaining	0 to 99 min, display 99 if >99 min	1 minute
• Total Ascent Time	0 to 99 min, display - - if >99 min	1 minute
• No Decompression Deep Stop Time	2:00 to 0:00 min:sec	1 second
• No Decompression Safety Stop Time	5:00 to 0:00 min:sec	1 second
• Decompression Stop Time	0 to 999 min	1 minute
• DIVE/GAUGE Elapsed Dive Time	0 to 999 min	1 minute
• Free Elapsed Dive Time (< 9 min)	0:00 to 9:59 min:sec	1 second
• Free Elapsed Dive Time (≥ 10 min)	10 to 999 min	1 minute
• Surface Interval Time	0:00 to 23:59 hr:min	1 minute
• Free Surface Interval Time	0:00 to 59:59 min:sec, then 1:00 to 23:59 hr:min	1 second 1 minute
• Time to Fly & Desaturate	23:50 to 0:00 hr:min* <i>* starting 10 min after the dive</i>	1 minute
• Temperature	-18 to 60° C (0 to 99° F) if outside of temp range, then displays - -	1°
• Time of Day	0:00 to 23:59 hr:min	1 minute
• Free Countdown Timer	59:59 to 0:00 min:sec	1 second
• Violation Countdown Timer	23:50 to 0:00 hr:min	1 minute

Max Functional Depth:

- Dive/Free/Gauge **Limit:**
100 m (330 ft)

ABBREVIATIONS/TERMS

ACT = Activation	HOME = Home Time Zone
AL = Alarm	IMP = Imperial (measure)
ALT = Alternate	LAST = Previous (dive)
ASC Bar Graph = Ascent Rate	LO = Low (battery)
ATA = Standard Atmosphere (unit)	M = Meters (depth)
AUD = Audible Alarm	MET = Metric
AWAY = Secondary Time Zone	MFD = Maximum Functional Depth (equipment limits)
BATT = Battery	MIN = Minutes (time)
CDT = Countdown Timer	MOD = Maximum Operating Depth
CF = Conservative Factor	N ₂ = Nitrogen
CHNG = Change	NDL = No Decompression Limit
CHRO = Chronograph	NDC = No Decompression (DTR)
DA/dA = Depth Alarm (Free Dive)	NO DECO = No Decompression (DTR)
DCS = Decompression Sickness	O ₂ = Oxygen
DECO = Decompression	O ₂ MIN = Oxygen Time Remaining (DTR)
DFLT = Default	O ₂ SAT = Oxygen Saturation
DS = Deep Stop	PC = Personal Computer (download)
DSI = Dive Surface Interval	PLAN = Dive Planner
DTR = Dive Time Remaining	PO ₂ = Partial Pressure of O ₂ (ATA)
DUAL = Dual Time Zones Displayed	SAFE = Safety (stop)
DURA = Duration (backlight)	SAT = Desaturation Time
EDT = Elapsed Dive Time	SEA = Sea Level
EL = Elevation (altitude)	SEC = Seconds (time)
ERR = Error	SHO = Show
FLY = Time To Fly	SLO = Slow Down
FO ₂ = Fraction of Oxygen (%)	SN = Serial Number
FORM = Format (date, time)	SR = Sample Rate
FREE = Free Dive Mode	SS = Safety Stop
FT = Feet (depth)	SURF = Surface
GAU/GAUG/GAUGE = Digital Gauge Dive Mode	TAT = Total Ascent Time (Time To Surface)
GLO = backlight	TLBG = Tissue Loading Bar Graph
GTR = Gas Time Remaining	VARI Bar Graph = Variable Ascent Rate
H ₂ O = Water	VIO/VIOL = Violation
HIST/HIS = History	

AQUA  LUNG®

www.aqualung.com